

The MT Flying Manual

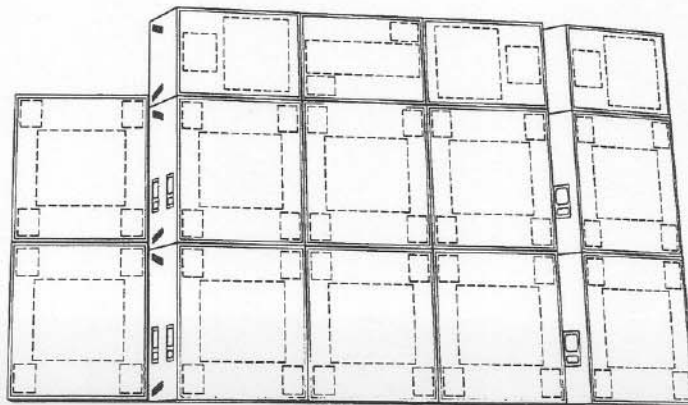
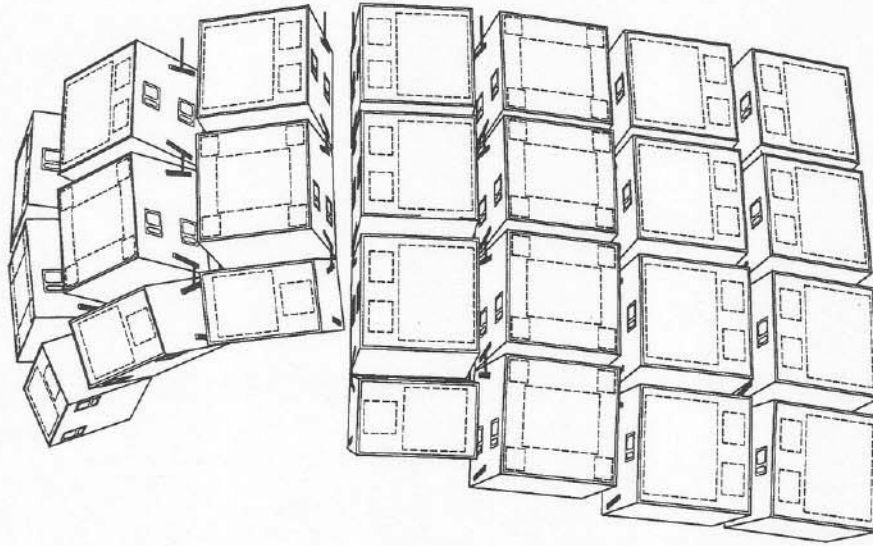

WARNING

This manual details general rigging practices appropriate to the sound industry, as they would apply to the rigging of Electro-Voice MT loudspeaker systems. It is intended to familiarize the reader with standard rigging hardware and techniques for suspending MT loudspeaker systems overhead. Only persons with the knowledge of proper hardware and safe rigging techniques should attempt to suspend any sound systems overhead. Prior to suspending any Electro-Voice MT loudspeaker systems overhead, it is essential that the user be familiar with the strength ratings, rigging techniques and special safety considerations outlined in this manual. The rigging techniques and practices recommended in this manual are, of necessity, in general terms to accommodate the many variations in loudspeaker arrays and rigging configurations. As such, the user is expressly responsible for the safety of all specific MT loudspeaker-array designs and rigging configurations and to ensure that all local safety regulations are followed.

All of the general rigging material contained in this manual is based on the best available engineering information concerning materials and practices, as commonly recognized in the United States, and is believed to be accurate at the time of the original printing. As such, the information may not be directly applicable in other countries. Furthermore, the regulations and requirements governing rigging hardware and practices may be superseded by local regulations. It is the responsibility of the user to ensure that any Electro-Voice loudspeaker system is suspended overhead in accordance with all current federal, state and local regulations.

All specific material concerning the strength ratings, rigging techniques and safety considerations for the MT loudspeaker systems is based on the best available engineering information concerning the use and limitations of the products. Electro-Voice continually engages in testing, research and development of its loudspeaker products. As a result, the specifications are subject to change without notice. It is the responsibility of the user to ensure that any Electro-Voice loudspeaker system is suspended overhead in accordance with the strength ratings, rigging techniques and safety considerations given in this flying manual and any flying-manual update notices. The user is urged to register with Electro-Voice, to automatically receive future product-update information involving the safety or performance of the MT systems. (See the "MT User Registration" section in this manual for details how on to register.)

Electro-Voice, Inc.

February, 1992

TABLE OF CONTENTS

	Page
WARNING	inside front cover
THE MT CONCEPT	1
THE BASIC MT RIGGING PRIMER	2
Anatomy of the MT Flying System	2
The Hardware	3
CONSTRUCTING ARRAYS	4
Coverage Patterns	4
Balancing the Enclosures	5
Array Building Blocks and Configurations	6
Array Building Blocks	6
Array Configurations	8
Grid Design for the MT Systems	11
STRENGTH RATINGS, SAFETY FACTORS AND SPECIAL CONSIDERATIONS	14
Strength Ratings and Safety Factors	14
Array Considerations	16
Grid/Building-Structural-Support Considerations	17
Rigging-Strap-Assembly Considerations	18
Redundant-Rigging-Hardware Considerations	18
INSPECTION, MAINTENANCE AND PRECAUTIONS	19
MT-System Components	19
MT-Loudspeaker Systems	19
Rigging-Strap Assemblies	19
Associated Hardware	19
Grid Assembly	19
Chain Hoists	19
Building Structural Supports	19
Mechanical Components	19
WARRANTY	19
REFERENCES	19
MT USER REGISTRATION	20

THE MT CONCEPT

To achieve the SPL and coverage required for high-level sound reinforcement, large loudspeaker arrays are needed. These arrays consist of many drivers in many boxes aimed in the same basic direction. The consequence is overlapping coverage patterns, resulting in lobing and interference patterns throughout the audience area. Because the MT-4A and MT-2A concert-sound loudspeaker systems use multiple drivers manifolded in each frequency band (four in the MT-4A and two in the MT-2A), less MT enclosures need to be hung to achieve the required SPL than are necessary with conventional systems. The result is smaller arrays. In addition, the MT systems maintain a true constant-directivity pattern both horizontally and vertically. Fewer sources and constant directivity in an array means less destructive interference for better audience coverage and uniform sound coverage throughout the listening area. This format is unique to the patented Manifold Technology® from Electro-Voice.

The MT systems lend themselves to easy array construction. The MT-4A combination is a two-box system with identically dimensioned 36-inch x 36-inch x 29.9-inch modules. With grilles in place, the MTL-4A low-frequency module is indistinguishable from the 60° x 40° MTH-4A midbass/midrange/high-frequency module. This allows the option of either flying the bass or stacking woofers on the floor for maximum efficiency - or even a combination of the two - while still preserving the uniform appearance of both the ground stack and the flown array. The MTH-4A box is essentially symmetrical top-to-bottom, allowing the creation of mirror-image arrays by simply turning the cabinet upside down. Additionally, the box front is perfectly square, allowing even more flexibility in array construction by the ability to rotate the 60° x 40° MTH-4A pattern for wider vertical coverage, without changing the array shape or size. The MT-2A combination is a two-box system consisting of the MTL-2A low-frequency module and the MTH-2A midbass/high-frequency modules. There are two versions of

the MTH-2A; the 90° x 40° MTH-2/94A and the 60° x 40° MTH-2/64. All three systems have the same 36-inch x 22.5-inch x 29.9-inch outside dimensions; however, the MTH-2/64 has a 30° trapezoidal enclosure. In addition, the midbass- and high-frequency horns in the MTH-2A systems may be rotated 90°, offering unparalleled flexibility in array construction. The MT-2A systems may be used alone or integrated into larger arrays with the MT-4A systems.

Because sound coming from numerous loudspeakers should arrive at any seat at the same time, the speakers in an array should be curved as if mounted on the outside of an imaginary sphere. The speakers must be close-spaced to minimize lobing and maximize coupling and each speaker must be accurately aimed. The apparent source then becomes the single point at the center of the sphere. The horizontal curve is simply achieved by hanging the cabinets closely spaced, aimed outward at diverging angles. The vertical curve is much more difficult to obtain. The MT-4A and the MT-2A systems utilize a unique two-point suspension system, shown in Figure 1, and are the only commercially available systems that achieve all of the design goals for true point-source-array design. To tilt an MT enclosure, straps attached on two sides of the enclosure are moved back along tracks which angle toward the cabinet's edge. Moving the attachment point towards the back automatically increases the space between the cabinets to accommodate the greater angle, with the length of the strap remaining the same.

The MTL-4A-series and MTH-4A-series are improved versions that replace the older MTL-4-series and MTH-4-series. The primary differences are the change in the electrical-input connectors from the ITT-Cannon EP™-type to the Neutrik Speakon™-type on both the MTL-4A and MTH-4A and the upgrade to the new and improved DH2A compression drivers in the MTH-4A mid-frequency section. Additionally, the strength of the rigging hardware has been increased in the flying versions. The MTL-2A and MTH-2/94A are improved versions that replace the MTL-2 and

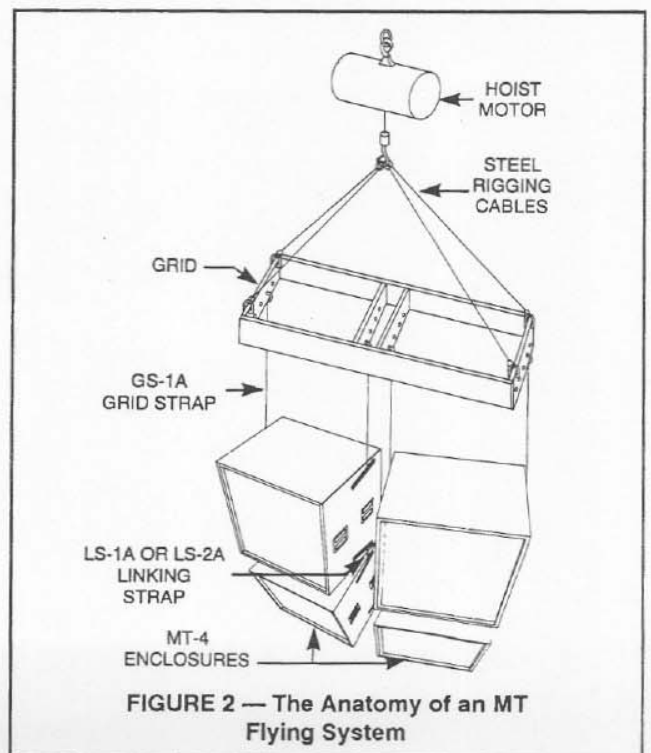
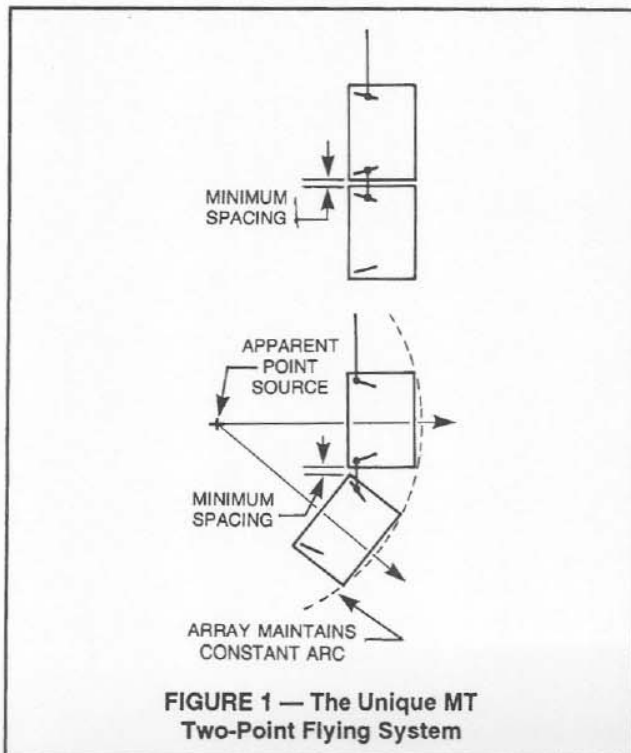

MTH-2/94. The primary differences are the change in the nominal impedance of the MTH-2/94A high-frequency section from 4 ohms to 8 ohms and the increased strength of the rigging hardware in the flying versions of both systems. The MTH-2/64 is a new addition to the MTH-2A series.

The MTL-2ACF, MTH-2/94ACF, MTL-4AF-series and MTH-4AF-series loudspeaker systems are identical to the original MTL-2CF, MTH-2/94CF, MTL-4F-series and MTH-4 F-series versions in size, weight, center of gravity, and rigging hardware type and placement. With the exception of the strength-rating differences, the newer and older models may be mixed without any special considerations.

All of the flying MT-2, MT-2A, MT-4 and MT-4A loudspeaker systems utilize the same rigging-strap accessories. The GS-1A grid straps and LS-1A linking straps are improved versions that replace the older GS-1 and LS-1. The LS-2A is a new linking strap that is longer than the LS-1A.

THE BASIC MT RIGGING PRIMER

Anatomy of the MT Flying System

A basic four-cabinet flying system is shown in Figure 2, illustrating the integral components that make up a typical MT system. The top cabinets are the starting points for constructing the array. These cabinets are first secured to a grid through the use of two grid straps per cabinet (the Electro-Voice GS-1A grid straps are recommended).

The MT-4 cabinets are equipped with two pieces of track to which the grid straps attach. The linear positioning of the attachment points determine the vertical angling of the cabinet. The remaining ends of the grid straps are then secured to the cross members of the grid. The relative positioning of the straps along the cross members determine the relative horizontal angle between the two cabinets. A second row of cabinets may be added below the original two by utilizing linking straps (the Electro-Voice LS-1A and LS-2A linking straps are recommended) that attach from the two lower track pieces of the first cabinets to the two upper track pieces of the second cabinets. Additional

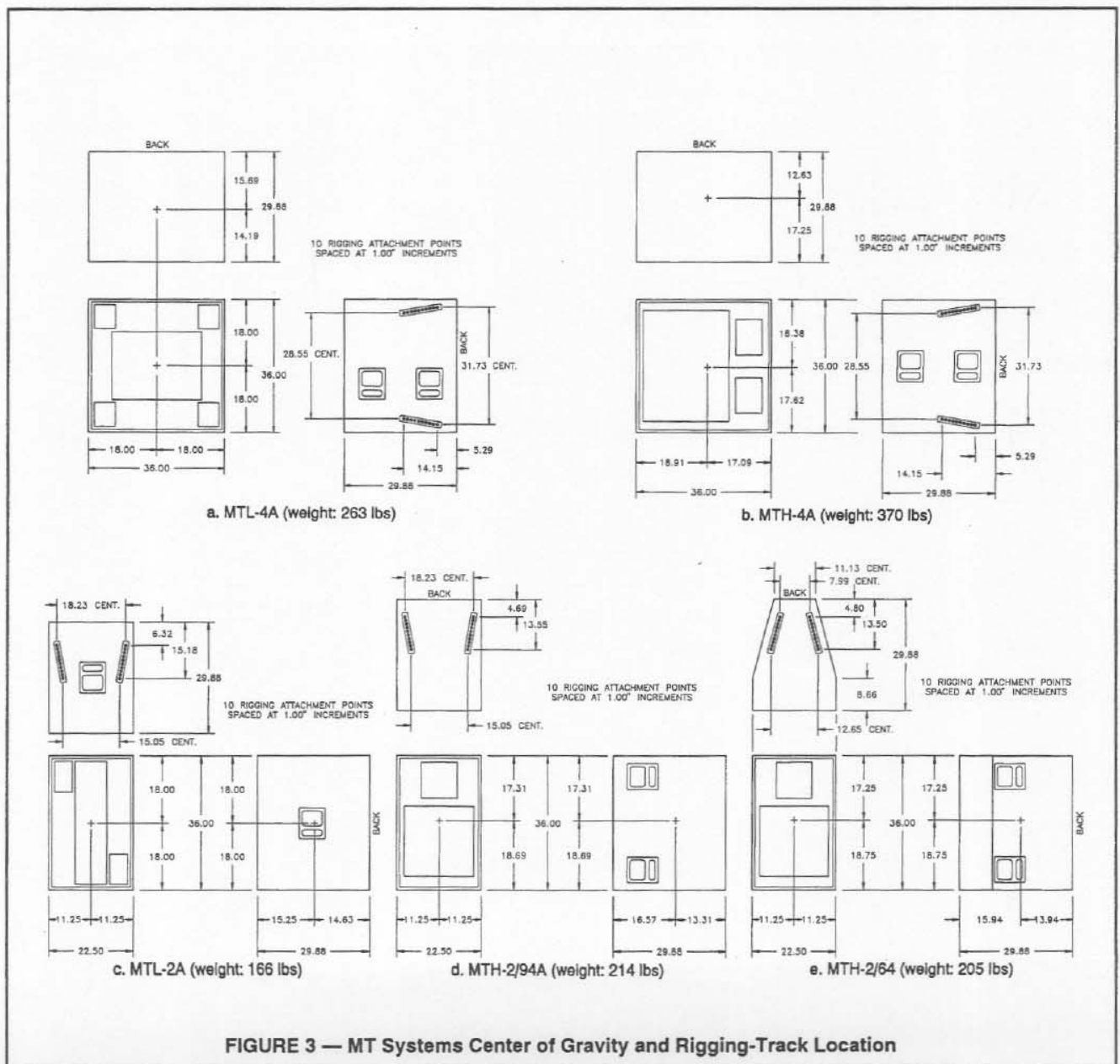

cabinets may be hung in succession in this fashion, as long as the load on any of the enclosures or rigging straps does not exceed their safe working load. The loudspeaker-array-grid assembly is then raised into position by a motorized chain hoist (or hoists) of sufficient load rating. Note that the weight of such an array can be quite substantial and the building structural supports to which the hoists are attached must be capable of supporting such a load with a sufficient safety factor. In permanent installations, the chain hoists are often eliminated with the grid assembly being secured directly to the building structure.

The Hardware

The MT flying system utilizes the highest-tech aircraft hardware available for securing heavy loads. Four pieces of aircraft-type "L-Track" fittings, specially machined extrusions of 7075-T6 aluminum-alloy material, are mounted in each enclosure. The track pieces are secured to 6061-T6 aluminum-alloy brackets that are an integral part of the MT flying enclosure. The locations of the rigging track and center of gravity are shown in Figure 3 for each of the MT systems. The hardware system was designed for use with the Kinedyne #32102-1 and #32111-1 double-stud ring fittings. The GS-1A grid-strap and LS-1A and LS-2A linking-strap assemblies, shown in Figure 4, use the Kinedyne #32111-1 fittings. To attach the rigging straps to the cabinet, grasp the fitting between the thumb and first two fingers, as shown in Figure 5. Push in the locking pin (with your free hand) and lift the spring-loaded locking ring over the pin by pressing with your thumb. Continue to press with your thumb until the two legs of the fitting are fully exposed. Insert the two round feet of the legs into the round cutouts in the track and slide the fitting to the desired location,

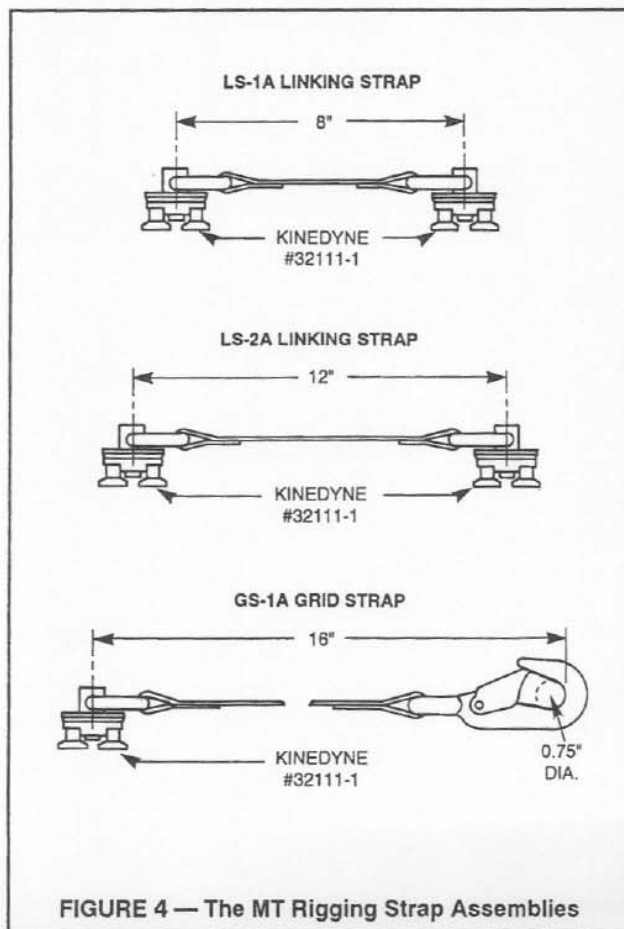

FIGURE 4 — The MT Rigging Strap Assemblies

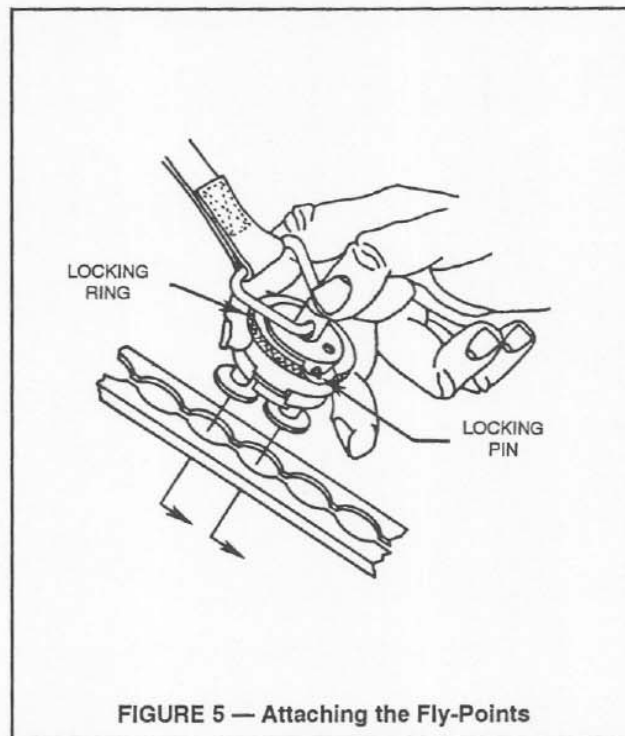

FIGURE 5 — Attaching the Fly-Points

having the main body of the fitting centered over one of the cutouts with the feet located on either side (i.e., the feet positioned directly under the teeth of the track). Release the locking ring. The round protrusion on the bottom of the fitting should lock into the round cutout in the track, with the locking ring retracting to its normal position, allowing the locking ring to reappear. (If the fitting does not lock into the track, nudge it along the track and wiggle as necessary until it does lock.) When locked, both the fitting and the locking ring will be immovable. To remove the fitting, reverse the procedure. **Always check to make sure that the fitting is securely locked into position and that the locking ring is immovable before lifting any MT enclosure overhead.**

The GS-1A, LS-1A and LS-2A strap assemblies have been specifically designed for optimal implementation of the MT flying system. All of the strap assemblies utilize the Kinedyne #32111-1 fittings. A safety hook is used on the GS-1A grid strap for attachment to the grid. The safety hook is perfectly suited for attaching to 5/8-inch shackles, or may be secured directly to the grid through a 7/8-inch diameter hole in the grid bar-stock material. All of the rigging straps utilize nylon-webbing strap material. Nylon webbing was chosen for its tremendous strength and because of its dynamic flexing capabilities. The force from any sudden jolt or shift in load is absorbed by the strap rather than transmitted directly to the speaker enclosure. Additionally, nylon is a flexible material that is easy to handle. The user is cautioned, however, that in certain permanent installation applications, the nylon material may not meet local fire regulations. In addition, if exposed to direct sunlight for long periods of time, the nylon material may deteriorate, resulting in reduced strength capability. The material may also deteriorate with extended exposure to hot, dry environments. In such instances, wire-rope or chain assemblies may have to be substituted.

Electro-Voice strongly urges that the user maintain a safety factor of at least 5:1 when implementing an MT flying system. The safety factor is defined as the ratio of the

ultimate-break-strength rating of the system to the actual applied load. In other words, the ultimate-break strength of each of the mechanical components in the system must be at least five times greater than the actual force applied to those components. The weakest component of an MT flying system determines the strength of the entire system. This includes the MT enclosures, the rigging-strap assemblies, the grid, the hoist and all other mechanical components and hardware.

All mechanical components used with an MT flying system (shackles, chains, hoists, wire-rope slings, nylon and/or polyester slings, etc.) should be load rated. All load-rated hardware will typically have its load rating displayed on each piece in a visible location. Typical ratings are denoted as the static-working load (SWL), or the working-load limit (WLL). These ratings generally assume a safety factor of 5:1 (this would result in a component with a working-load rating of 1,000 pounds having an ultimate-break-strength rating of 5,000 pounds); however, the user should consult the manufacturer to confirm the rating. Occasionally, the load rating is given as the ultimate-break strength. This allows the user to calculate the safety factor directly for a given load. Both the ultimate-break strength and the working-load limit for a 5:1 safety factor will be presented in this manual for the strength of the Electro-Voice MT enclosures and rigging hardware, as well as the Electro-Voice GS-1A, LS-1A and LS-2A rigging-strap accessories.

The MTL-2ACF, MTH-2/94ACF, MTL-4AF-series and MTH-4A F-series loudspeaker systems are identical to the original MTL-2CF, MTH-2/94CF, MTL-4F-series and MTH-4 F-series versions in size, weight, center of gravity, and rigging hardware type and placement. However, the newer models have slightly increased strength ratings. With the exception of the strength-rating differences, the newer and older models may be mixed without any special considerations. The user is cautioned that there were errors in the strength ratings given in the original printing of the "MT-4 FLYING OPTION USER'S GUIDE" (EV Part No. 530761) and the "ADDENDUM TO THE MT-4 FLYING OPTION USER'S GUIDE - FLYING THE MT-2" (EV Part No. 531470). Complete strength-rating specifications for both the newer and older versions are presented in this manual. Hence, the user should use the specifications given in the "Strength Ratings, Safety Factors and Special Considerations" section in this manual when designing arrays for any of the MT-2, MT-4, MT-2A and MT-4A loudspeaker systems.

CONSTRUCTING ARRAYS

Coverage Patterns

The MTH-4A has a square-front enclosure (36-inch x 36-inch x 29.9-inch-deep) and exhibits a 60° x 40° constant-directivity coverage pattern. Although the horns are not rotatable in the MTH-4A, the coverage pattern may be rotated by simply turning the enclosure on its side, as shown in Figure 6. When oriented for a 60°H x 40°V coverage pattern, the rigging track is located on the sides of the enclosure. When oriented for a 40°H x 60°V pattern, the track then appears at the top and bottom of the enclosure. Additionally, the MTH-4A may be turned upside down from the configurations shown in Figure 6 for the creation of mirror-image arrays. The MTL-4A enclosure has the same dimensions and rigging-track orientation and may be rotated to match the MTH-4A. (Due to the non-directionality of low frequencies, the coverage pattern of the MTL-4A

systems is affected more by the array configuration than the orientation of the individual enclosures. Hence, the affect of rotating low-frequency enclosures can be considered negligible.) Because the MT-4A enclosures have a square front, the appearance of the array is not disrupted by rotating the enclosures. Furthermore, the EV logo on the front of the MT-4A enclosures may be rotated, if desired, to match the orientation of the enclosure.

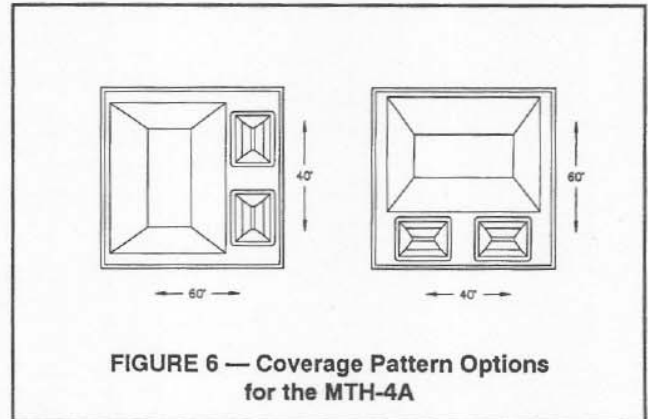

The MTH-2/94A has a rectangular-front enclosure (36-inch x 22.5-inch x 29.9-inch-deep) and exhibits a 90° x 40° constant-directivity coverage pattern. Both the midbass- and high-frequency horns are rotatable in the MTH-2/94A, allowing a 90°H x 40°V or a 40°H x 90°V pattern to be achieved with the enclosure oriented in either the "tall" or "wide" configuration as shown in Figure 7. When oriented in the "tall" configurations, the rigging track is located on the top and bottom of the enclosure. When oriented in the "wide" configuration, the rigging track appears on the sides of the enclosure. Additionally, the MTH-2/94A may be turned upside down from the configurations shown in Figure 7 for the creation of mirror-image arrays. The MTL-2A enclosure has the same dimensions and rigging-track configuration and may be oriented to match the MTH-2/94A. (Like the MTL-4A systems, the coverage pattern of the

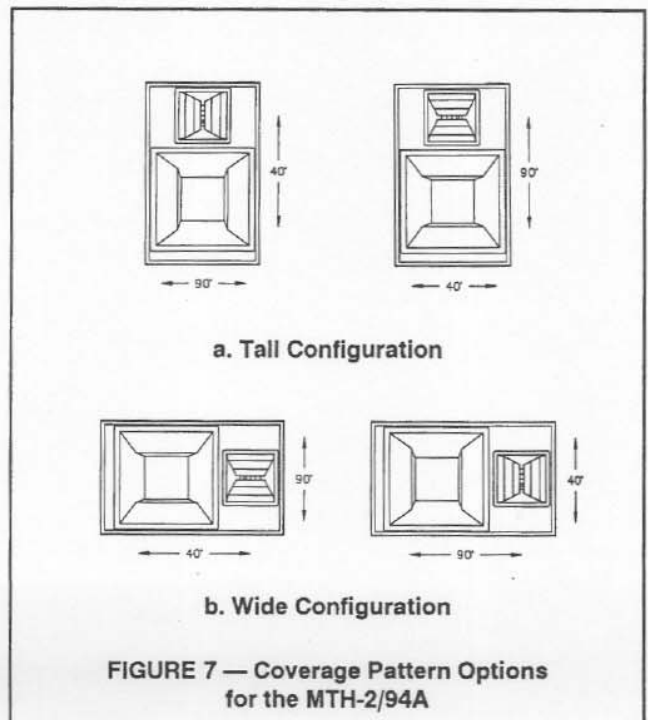

MTL-2A systems is affected more by the array configuration than the orientation of the individual enclosures, resulting in the low-frequency-enclosure orientation to be considered negligible.) Like the MT-4A systems, the EV logo on the front of the MT-2A enclosures may be rotated to match the orientation of the enclosure.

While the MTH-2/64 has the same overall outside dimensions of the MTH-2/94A and MTL-2A (36-inch x 22.5-inch x 29.9-inch-deep), the shape of the enclosure is trapezoidal instead of rectangular. The MTH-2/64 exhibits a 60° x 40° constant-directivity coverage pattern. Like the MTH-2/94A, both the midbass- and high-frequency horns are rotatable in the MTH-2/64, allowing a 60°H x 40°V or a 40°H x 60°V pattern to be achieved with the enclosure oriented in either the "tall" or "wide" configurations as shown in Figure 8. When oriented in the "tall" configuration, the rigging track is located on the top and bottom (the trapezoidal end) of the enclosure. When oriented in the "wide" configuration, the rigging track appears on the sides of the enclosure. The MTH-2/64 may also be turned upside down from the configurations shown in Figure 8 for the creation of mirror-image arrays. Because the MTH-2/64 enclosure has the same overall dimensions and rigging-track configuration as the MTH-2/94A and MTL-2A, the MTH-2/64 may be integrated into arrays with the other MT-2A systems. Like the others, the EV logo on the front of the MTH-2/64 enclosures may be rotated to match the orientation of the enclosure.

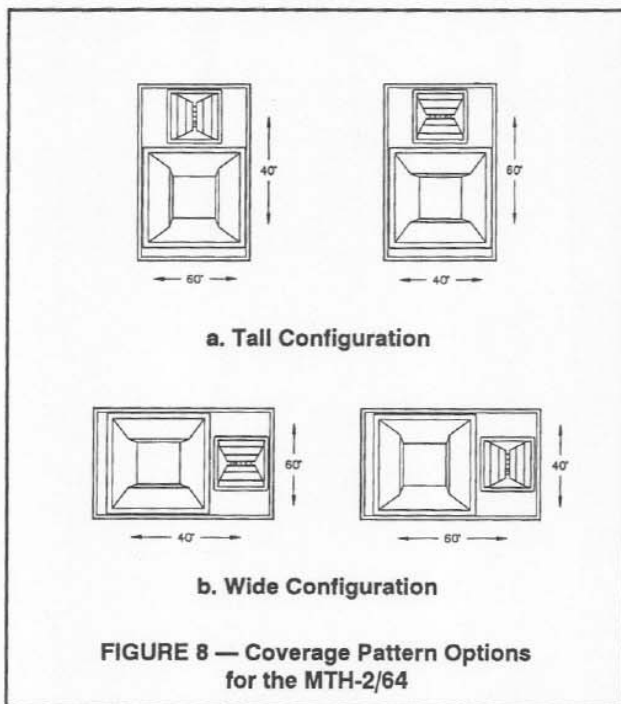

The useful range of coverage angles and acoustic-output capabilities of the MTH-4A, MTL-4A, MTH-2/94A, MTH-2/64 and MTL-2A systems, combined with the rotational-coverage-pattern capability and the unique rigging concept, offer the array designer unparalleled flexibility in constructing loudspeaker-system arrays. The MT-2A and MT-4A systems may be mixed together in a wide variety of combinations to achieve the proper balance of sound-pressure level and coverage throughout the listening area. A number of array examples will be presented in the following sections.

Balancing the Enclosures

The vertical angle of the flying MT enclosure may be adjusted by choosing different positions of attachment along the rigging track on the enclosure. There are a total of ten attachment points allowing for a wide variety of angles. Although the center of gravity is slightly different for each of the MT-2A and MT-4A systems, the balancing concept is the same. The further the attachment point is towards the back of the cabinet, the greater the downward angle, as shown in Figure 9. As the attachment point is moved forward, the cabinet will have less downward angle and, at the furthest point forward, point approximately straight ahead or have a slight upward tilt. This principle holds true when hanging any of the MT-2A or MT-4A systems in any of the orientations shown in Figures 6 through 9. (Note that changing the orientation of the midbass- and high-frequency horns in the MTH-2A systems will not affect the balance of the enclosures.)

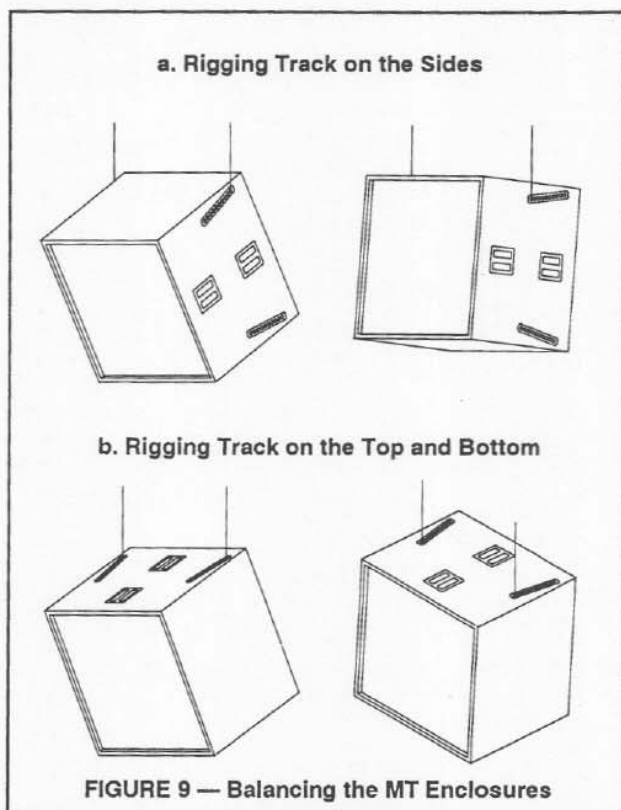

Vertical arrays are constructed by hanging cabinets from one another in succession. Both the curvature of the array and the angles of the individual cabinets are controlled by the attachment-point positions. The shape of the array curve is determined by the position on the lower track of an already hanging cabinet from which the next cabinet is hung - the further back the attachment point is on the upper box, the further back the lower cabinet is shifted and, hence, the greater the curvature of the array. The goal is to have the back top and bottom edges of adjacent cabinets nearly touching.

Hanging one cabinet from another affects the angle of the first. This is best demonstrated in an example. In Figure 10a, one MT enclosure is hung so that it points straight ahead and a second is added below. The addition of the second enclosure causes the first (the top cabinet) to point upward. Shifting the upper attachment point of the first

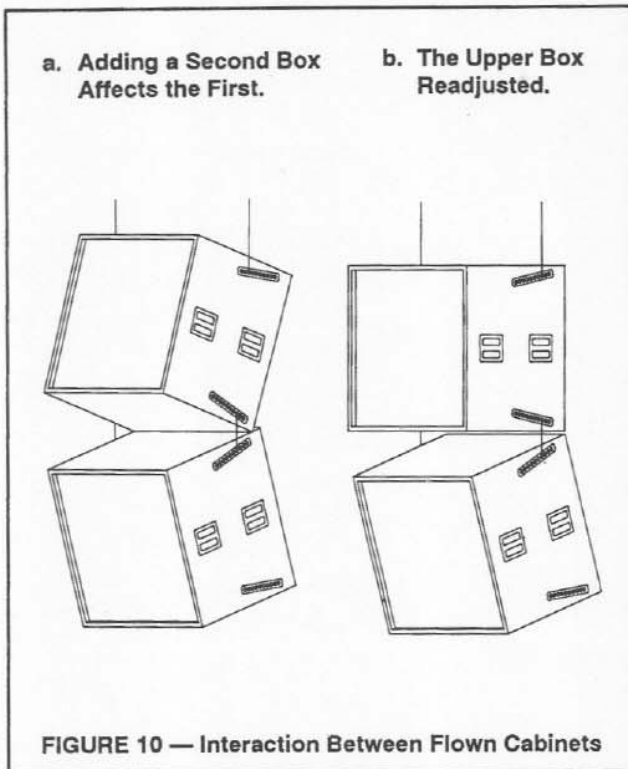

cabinet back, as shown in Figure 10b, counteracts the additional load and results in the upper cabinet pointing straight ahead again. Note that this change has no effect on the angle of the lower cabinet. Additional MT enclosures may be hung in succession in this fashion, creating a vertical line array, as long as a sufficient safety factor is maintained.

Array Building Blocks and Configurations

In this section, a variety of array building blocks and configurations are presented that are useful for many commonly encountered sound reinforcement situations. The system designer should not consider these examples to be the limit of possibilities, but rather an introduction to the MT array-design concept. These examples might serve as a starting point from which modifications may be made to tailor an array to meet exact requirements.

Array Building Blocks: A variety of array building blocks are presented in Figures 11 through 18. Included in these figures are notations indicating the positions of the rigging-attachment points on the cabinets, the downward angle of each cabinet and the rigging straps used for suspending the cabinets. There are 10 rigging-attachment positions on the rigging track mounted on each of the MT-2A and MT-4A enclosures. The convention used in this manual is as follows: Position #1 is at the extreme end of the track closest to the back of the enclosure, while position #10 is at the extreme end of the track closest to the front of the enclosure

A very basic building block would be a full-range array made up of a single MTL-4A low-frequency system and MTH-4A mid/high-frequency system. A full-range MT-4A building block having a 60°H x 40°V pattern is shown in Figure 11. The MTH-4A is hung below the MTL-4A, allowing maximum flexibility of aiming the mid and high frequencies. Due to the non-directionality of low frequencies from a

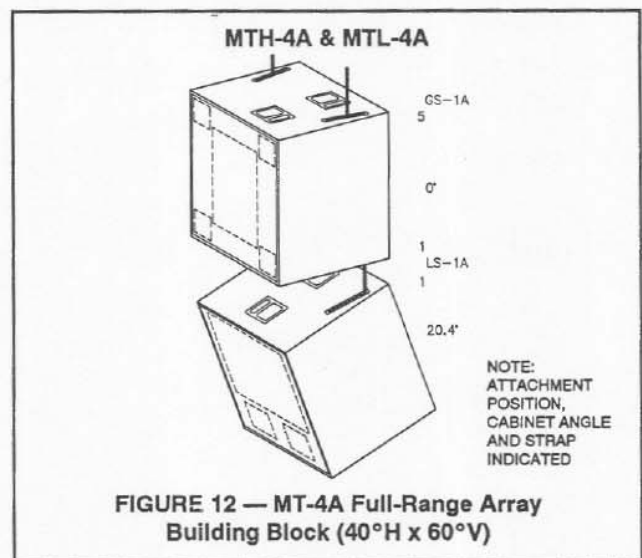
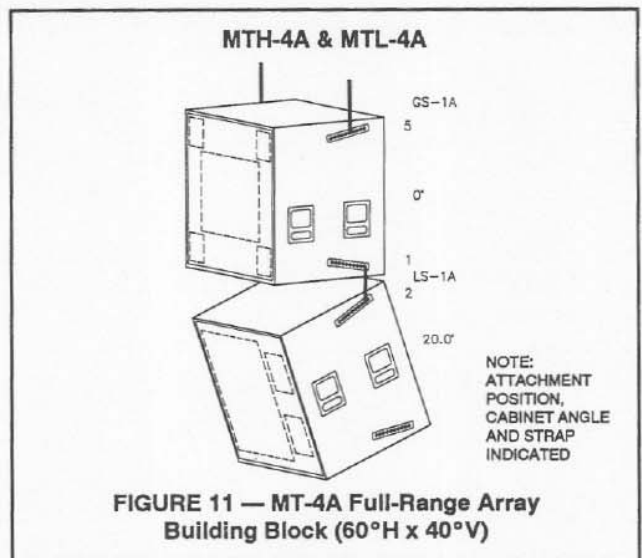

single enclosure, the MTL-4A does not necessarily need to be aimed down to match the MTH-4A. The same cabinets utilized in a 40°H x 60°V configuration are shown in Figure 12. Again, the MTH-4A is on the bottom, but this time with the high-frequency horns down, allowing the closest possible spacing between the midbass- and low-frequency sections.

Where lesser acoustic output is required, a full-range-array building block made up of a single MTL-2A low-frequency system and MTH-2A mid/high-frequency system might be used. Full-range building blocks using the MT-2A systems in the "wide" configuration are shown in Figure 13. The MTH-2/94A would be used when a 90° x 40° pattern was required, while the MTH-2/64 would be used for a 60° x 40° pattern. The midbass- and high-frequency horns may be oriented in either direction as required. Full-range building blocks using the MT-2A systems in the "tall" configuration are shown in Figure 14. As with the MT-4A examples, the MTL-2A systems do not necessarily need to be aimed down to match the MTH-2A systems, because of the non-directionality of the low frequencies from a single enclosure. Additionally, the midbass- and high-frequency horns may be oriented as the situation requires.

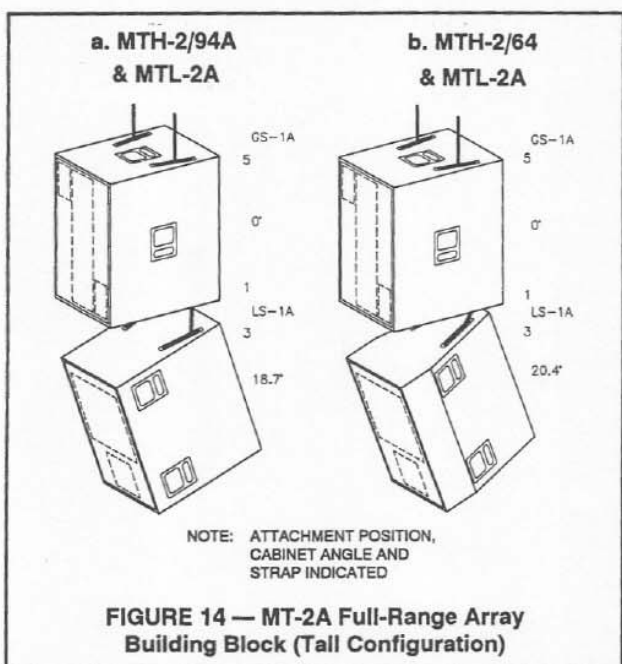
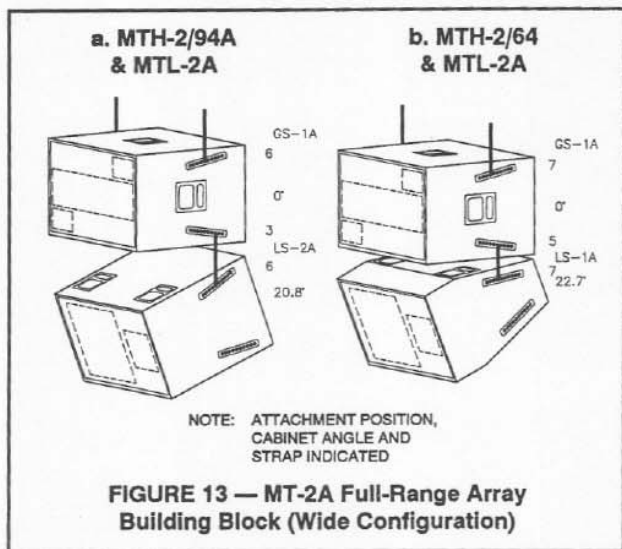

A medium-power full-range-array building block with both long- and short-throw elements is shown in Figure 15. This array consists of an MTH-4A system in the 60°H x 40°V configuration at the top, with an MTL-4A in the middle, followed by an MTH-2/94A in the "wide" configuration at the bottom with a 90°H x 40°V pattern. Having the MTH-2/94A on the bottom allows greater freedom to angle the 90° x 40° pattern downward where the coverage is needed.

For higher-power applications, line-array building blocks of MTH systems and MTL systems may be constructed separately. Figure 16a shows a medium-power line array with two MTH-2/64 systems in the "wide" configuration at the top with 60°H x 40°V patterns for long-throw capability, followed by a single MTH-2/94A at the bottom, in the "wide" configuration with a 90°H x 40°V pattern. A matching column of three MTL-2A systems is shown in Figure 16b. The MTL-2A systems have downward angles that match the MTH-2A systems. While the angling down of the bottom MTL-2A cabinets will have little affect at low frequencies, it will ensure that the upper-bass coverage of the MTL-2A

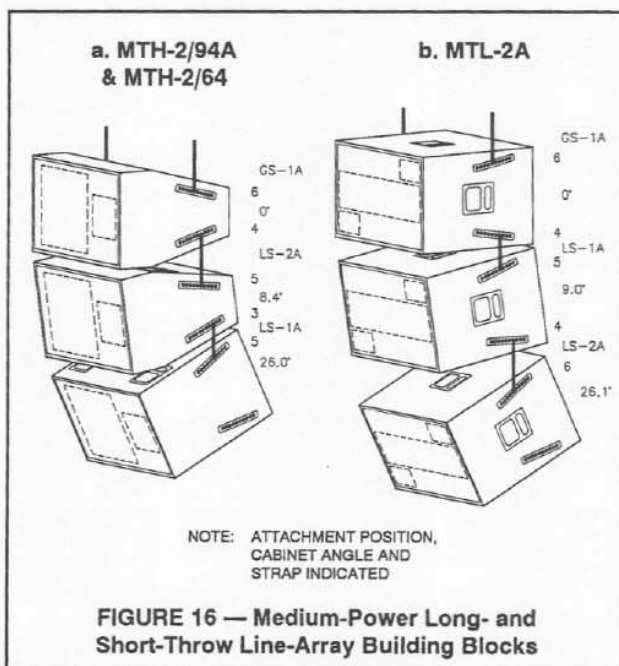
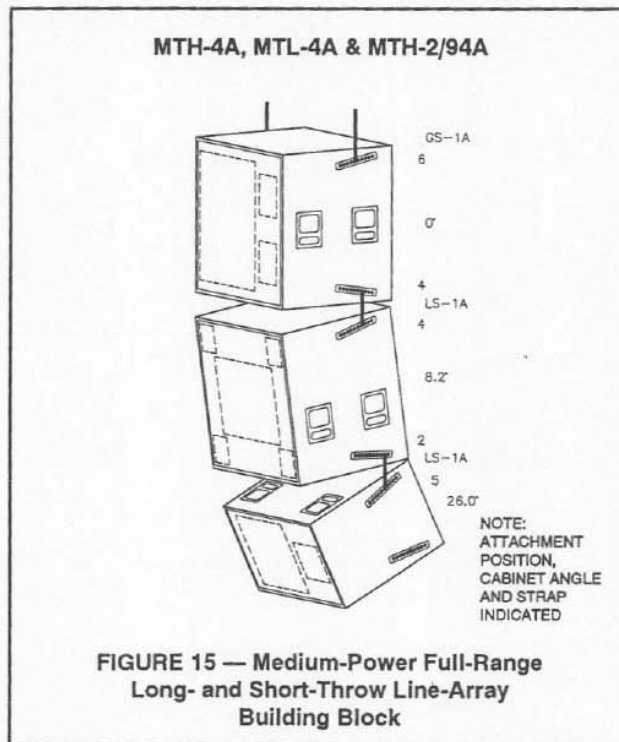

systems matches the lower-midbass coverage of the MTH-2A systems. This is necessary because hanging (or stacking) columns of multiple MTL systems will result in increased vertical directivity in the upper-bass region.

In large rectangular venues where the sound system is flown over the stage at one end of the room, it is particularly effective to arrange MT enclosures in tall vertical columns to achieve a long-throw capability. This technique creates separate line arrays for the different frequency bands (low-, midbass- and mid/high-frequencies), allowing maximum vertical-pattern control with minimum lobing, while maintaining an accurate horizontal-coverage pattern. Figure 17a shows a high-power line array with three MTH-4A

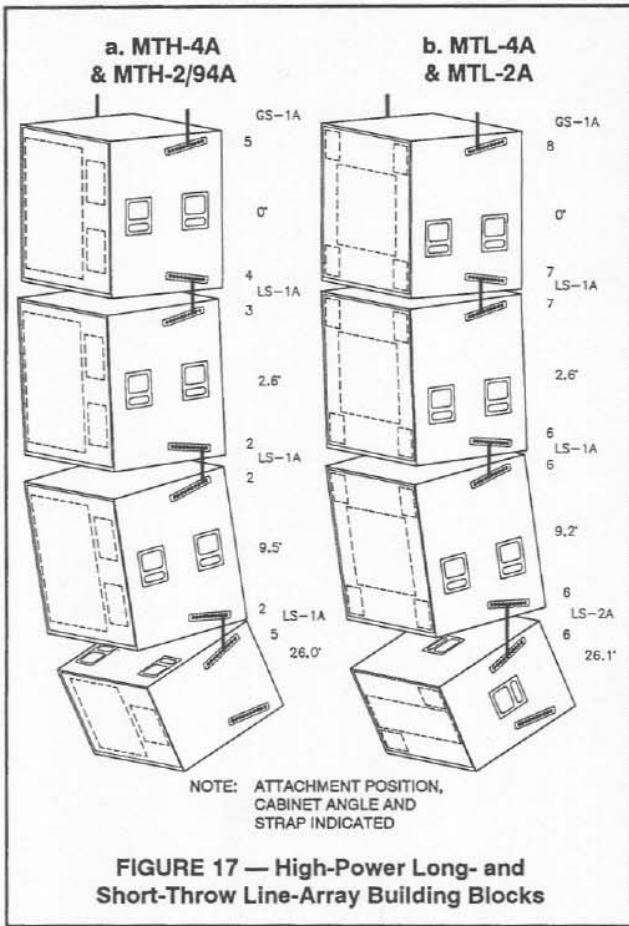

systems in the 60°H x 40°V pattern configuration at the top for long-throw capability, followed by a single MTH-2/94A at the bottom, in the "wide" configuration with a 90°H x 40°V pattern. A matching column of three MTL-4A systems and a single MTL-2A system is shown in Figure 17b. The MTL-4A and MTL-2A systems have downward angles that match the MTH-2A systems. As in the previous example, angling down the bottom low-frequency cabinets will ensure that the upper-bass coverage of the MTL systems matches the lower-midbass coverage of the MTH systems.

A very-high-power long-throw line array is shown in Figure 18a with four MTH-4A systems in the 60°H x 40°V pattern configuration. A matching column of four MTL-4A systems is shown in Figure 18b. As in the previous examples, the low-frequency cabinets are angled down to ensure that the upper-bass coverage of the MTL-4A systems matches the lower-midbass coverage of the MTH-4A systems.

When tall columns of MT loudspeaker systems are employed, the low-frequency directivity will be increased well beyond that of a single system. Line arrays like those shown in Figures 17 and 18 will maintain vertical directivity down below 200 Hz. At high frequencies, on the other hand, tall columns of MTH loudspeaker systems will maintain their vertical directivity. This is because the Electro-Voice HP horns used in the MTH systems have tightly controlled constant-directivity patterns in both the horizontal and vertical planes, minimizing interaction between horns and reducing beaming and lobing.

Array Configurations: The full-range building blocks in Figure 14 may be used as components of a distributed system or as elements of a clustered array. Figure 19

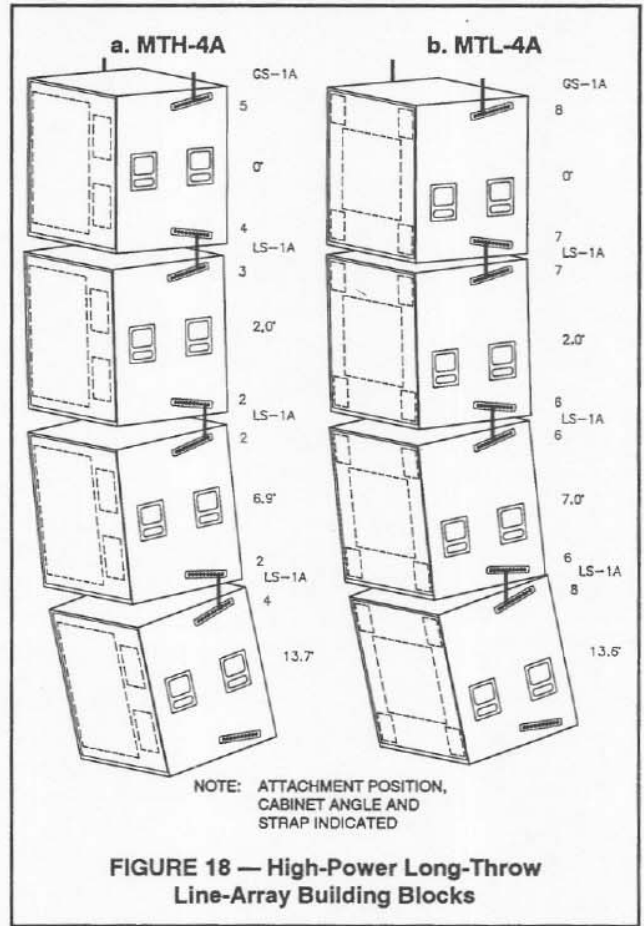

shows a cluster of three of the MTL-2A/MTH-2/94A combinations from Figure 14a. (The rigging-attachment points, rigging straps and cabinet angles are identical to those shown in Figure 14a.) The midbass- and high-frequency horns in the MTH-2/94A systems may be oriented in either the 90°H x 40°V or 40°H x 90°V configuration, depending on the required vertical coverage and the horizontal play angle between the cabinets. Figure 20 shows a cluster of three of the MTL-2A/MTH-2/64 combinations from Figure 14b. (The rigging-attachment points, rigging straps and cabinet angles are identical to

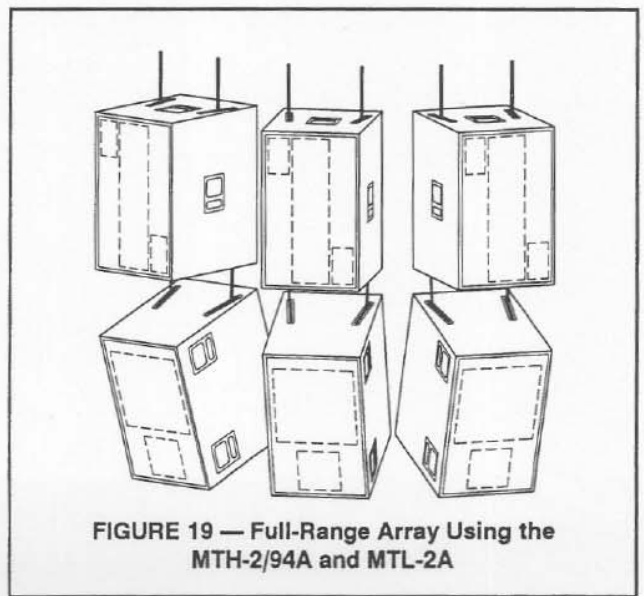

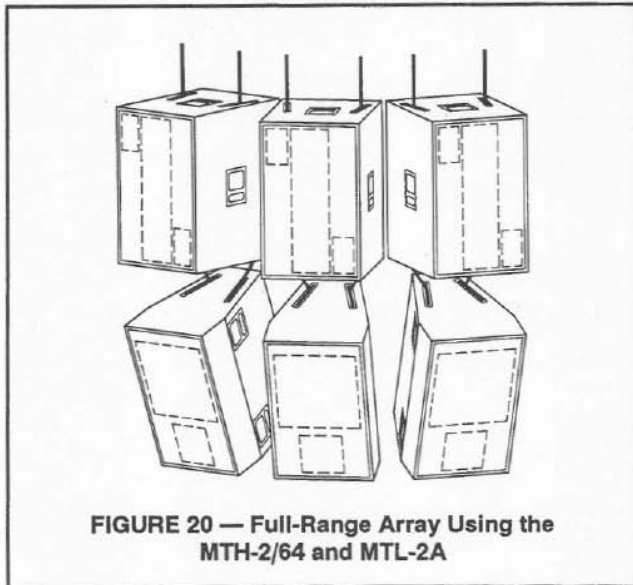

FIGURE 20 — Full-Range Array Using the MTH-2/64 and MTL-2A

those shown in Figure 14b.) As before, the midbass- and high-frequency horns in the MTH-2/64 systems may be oriented in either the 60°H x 40°V or 40°H x 60°V configuration, depending on the required vertical coverage and the horizontal splay angle between the cabinets.

The full-range building block in Figure 15 may also be used as components of a distributed system or as elements of a clustered array. Figure 21 shows a cluster of three of the MTL-4A/MTH-4A/MTH-2/94A combinations. (The rigging-attachment points, rigging straps and cabinet angles are identical to those shown in Figure 15.) This combination is particularly effective where a combination of long- and short-throw elements are required. Because the MTH-4A systems may only be oriented in the 60°H x 40°V configuration, the best results will be obtained with the MTH-2/94A systems oriented in the 90°H x 40°V configuration.

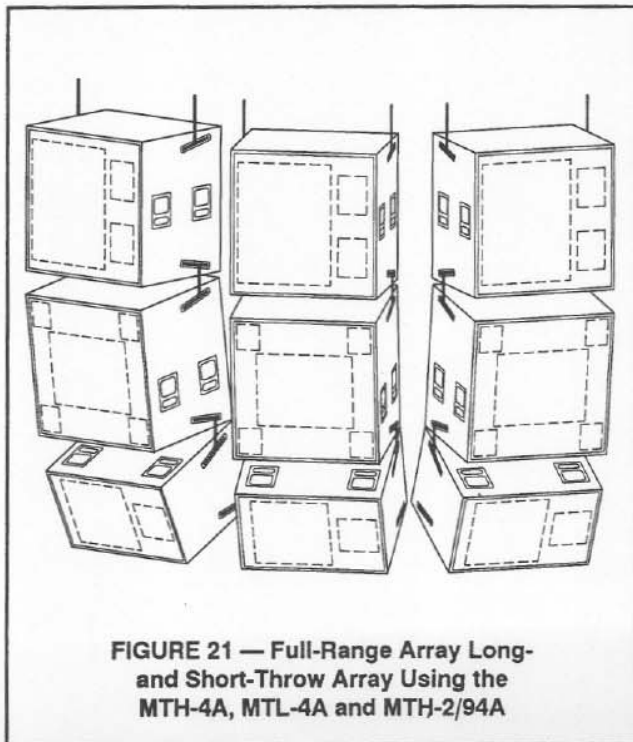

FIGURE 21 — Full-Range Array Long- and Short-Throw Array Using the MTH-4A, MTL-4A and MTH-2/94A

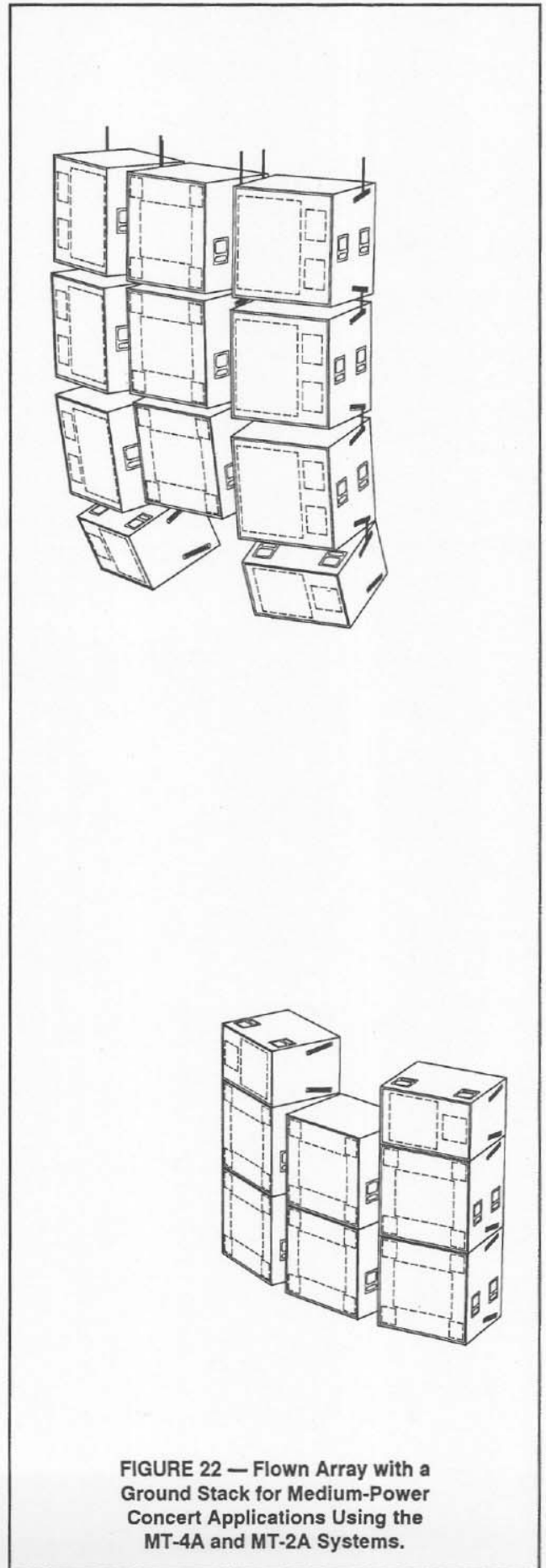

FIGURE 22 — Flown Array with a Ground Stack for Medium-Power Concert Applications Using the MT-4A and MT-2A Systems.

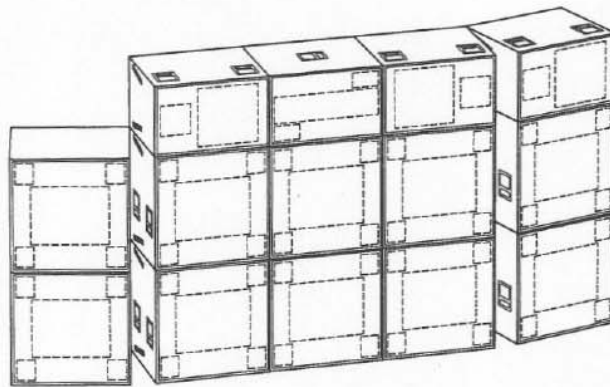
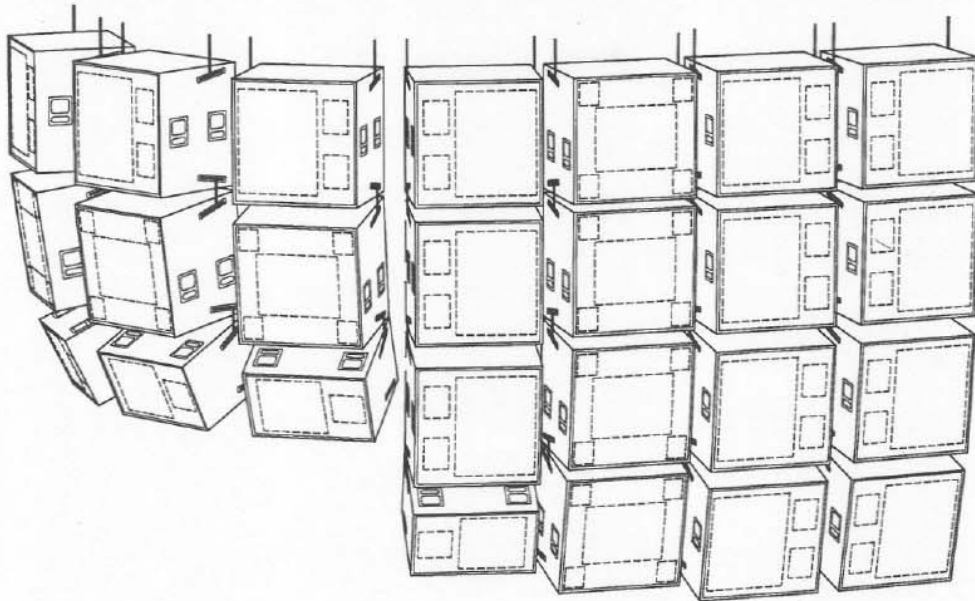

FIGURE 23 — Flown Array With Ground Stack for Very-High-Power Concert Applications Using the MT-4A and MT-2A Systems.

A medium-size concert system is shown in Figure 22. This array uses two columns of the MTH-4A/MTH-2/94A combinations from Figure 17a (one column is hung in mirror image) and one column of MTL-4A systems from Figure 17b (without the MTL-2A on the bottom). (The rigging attachment points, rigging straps and cabinet angles are identical to those shown in Figure 17.) Such an arrangement would be flown on either side of the stage. A ground stack would be added underneath each hang, consisting primarily of MTL-4A systems (on the floor for

maximum low-frequency efficiency) with two MTH-2/94A systems to cover the audience near the stage. Flying approximately one-third of the bass is recommended to achieve uniform low-frequency coverage in the upper seating banks along the sides of a long rectangular venue. The top three cabinets are aimed towards the back of the hall with the bottom cabinet angled down to cover the audience area nearer the array. Note that the ground stack is positioned behind the flown array as a continuation of the arc of the flown array.

One side of a large high-power concert system (stage right) intended for a large rectangular venue where the sound system is flown over the stage at one end of the room is shown in Figure 23. Two columns of MTH-4A systems (one in mirror image) from Figure 18a are shown pointed, primarily, straight ahead. (The inside column may be angled in slightly as necessary.) These systems will cover the center of the main floor. Moving further out, there is a single column of MTL-4A systems from Figure 18b pointed straight ahead. The MTL-4A column up in the air will help to achieve uniform low-frequency coverage in the upper seating banks along the sides of the venue. In addition, because of the height of the column (over 12 feet), these MTL-4A systems will maintain a controlled vertical-coverage pattern down to approximately 100 Hz, offering long-throw capability to the back of the hall in the upper-bass region. Next is a column of the MTH-4A/MTH-2/94A combination from Figure 17a angled outward slightly to cover the outside edge of the main-floor-seating area and the seating on the side banks. Angled sharply around the outside edges are three columns of the full-range MTH-4A/MTL-4A/MTH-2/94A combination from Figure 15. These systems will cover the seating banks along the sides of the stage. If the audience seating were to continue around the back of the stage, additional columns would be hung at the back of the stage. (The rigging-attachment points, rigging straps and cabinet angles for the flown MT loudspeaker systems are identical to those shown in Figures 15, 17 and 18.) The ground stack consists primarily of MTL-4A and MTL-2A systems (on the floor for maximum low-frequency efficiency) with three MTH-2/94A systems to cover the audience near the stage. Note that, as in the previous example, the ground stack is positioned behind the flown array, acting as a continuation of the arc of the flown array.

All of the techniques for constructing arrays as shown in Figures 19 through 23 may be expanded upon to create different arrays utilizing different combinations of MT-4A and MT-2A loudspeaker systems, as long as a sufficient safety factor is maintained. The user is urged to consult the "Strength Ratings, Safety Factors and Special Considerations" section of this manual before attempting to suspend any MT loudspeaker systems overhead.

Grid Design for the MT System

Electro-Voice does not manufacture grids for suspending MT loudspeaker arrays overhead. In the case of permanent installations, it is generally most efficient and cost effective to design a support system specific to the installation, taking into account the loudspeaker array(s) and the building structure. It may even be possible, in some circumstances, to eliminate the grid and secure the loudspeakers directly to the building structural supports. The sound system designer is instructed to evaluate each individual circumstance and design a support system tailored to the specific application.

In the case of touring concert sound, a few array formats, such as those shown in Figures 19 through 23, occur with great frequency. A set of "all-purpose" grids that would accommodate these formats and allow variations would be particularly useful. Two different grids are shown in Figure 24. The grid in Figure 24a will accommodate both the MT-4A and MT-2A systems oriented with the rigging track on the sides (as shown in Figures 11, 13, 15, 16, 17, 18, 21 22 and 23), as well as the MT-4A systems with the rigging track on the top and bottom (as shown in Figure 12). The grid in Figure 24b will accommodate only the MT-2A

systems with the rigging track on the top and bottom (as shown in Figures 14, 19, and 20). The grids may be constructed with a choice of different lengths, depending on whether the grid will support two, three or four columns of MT loudspeakers, in the case of the MT-4A/MT-2A grid in Figure 24a; or two or three columns in the case of the MT-2A grid in Figure 24b. Both grids use common 5/16-inch-thick structural-steel bar stock and require only simple welding techniques. These grids will allow the cabinets to be splayed horizontally inward or outward with angles up to nearly 30° for the MT-4A/MT-2A grid and 40° for the MT-2A grid. The maximum achievable splay angle may be less if the columns of loudspeaker cabinets are hung with a sharp curve in the array, or if the cabinets are angled down sharply (because the back corners of the bottom cabinets may touch).

Suggested rigging configurations for various arrays are shown in Figures 25 and 26. The loudspeaker systems may be attached directly to the grid with the GS-1A grid straps, or the grid straps may be attached to 5/8-inch shackles which are in turn secured to the grid. 5/8-inch shackles are secured to the top of the grid as pick points for hoisting. Flat washers (3/4-inch) should be used with the shackles to center the load on the eyebolt. 3/8-inch-diameter 6x19 IPS-IWRC wire-rope slings are used to secure the shackles at the top of the grid to the hoist. Whenever a two-legged bridle is indicated, each leg should be at least 36 inches long. Whenever a four-legged bridle is indicated, each leg should be at least 48 inches long.

The weight distribution of the grid will vary both side to side and front to back, depending on the particular loudspeaker-array configuration. There are a variety of attachment points on the underside of the grid that will allow the loudspeaker columns to be shifted until a front-to-back balance is achieved. There are also a variety of attachment points on the top of the grid that will allow the pick points to be shifted until a side-to-side balance is achieved. **A seriously imbalanced condition could have potentially disastrous results. The user should always test the balance of any load prior to the load being lifted overhead.**

Used properly, these flying configurations utilize the full-strength capability of the suggested grid design, maintaining the maximum safety factor. The user should never exceed the maximum load indicated for any of the indicated rigging configurations. The user is cautioned that other rigging configurations may lessen the safety factor. The load should always be raised (or lowered) slowly and evenly. Any sudden jolts or dynamic changes (occurring from rapid changes in speed, shifting loads, etc.) can result in impact forces many times greater than static dead-weight load,

Electro-Voice offers these grid designs only as suggestions and offers no guarantee of performance. If fabricated as detailed in Figure 24 and utilized as shown in Figures 25 and 26, the grids will (theoretically) have a safety factor in excess of 10:1 for the maximum loads indicated. Variances in the quality of materials and workmanship can substantially affect the strength of the grid. **The user is responsible for determining the strength of any constructed grid and the resulting safety factor for all array designs and rigging configurations.**

a. MT-4A/MT-2A Grid

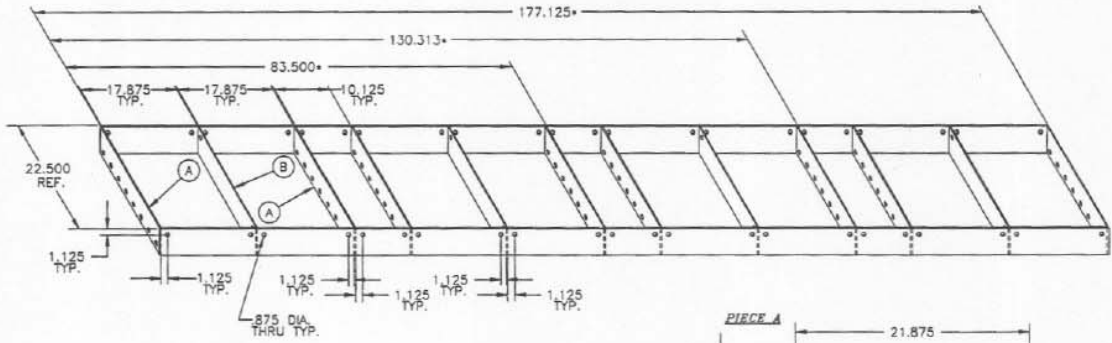

*CUT TO INDICATED LENGTH FOR 2, 3, OR 4 COLUMN GRID.

NOTES:

1. MAT'L: 5.000 x .313 THICK STEEL WITH ULTIMATE TENSILE STRENGTH OF 60,000 P.S.I. MINIMUM.
2. ALL DIMENSIONS IN INCHES.
3. TOLERANCES: ±.031
4. WELD .313 FILLET BOTH SIDES OF EACH TEE JOINT.
5. WELD .313 FILLET INSIDE EACH CORNER JOINT.
6. WELD .469 BACKING OUTSIDE EACH CORNER JOINT.

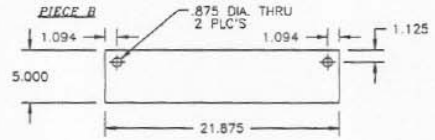
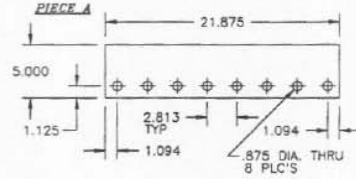

b. MT-2A Grid

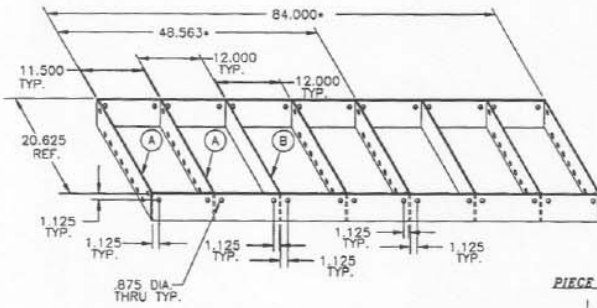

*CUT TO INDICATED LENGTH FOR 2, OR 3 COLUMN GRID.

NOTES:

1. MAT'L: 5.000 x .313 THICK STEEL WITH ULTIMATE TENSILE STRENGTH OF 60,000 P.S.I. MINIMUM.
2. ALL DIMENSIONS IN INCHES.
3. TOLERANCES: ±.031
4. WELD .313 FILLET BOTH SIDES OF EACH TEE JOINT.
5. WELD .313 FILLET INSIDE EACH CORNER JOINT.
6. WELD .469 BACKING OUTSIDE EACH CORNER JOINT.

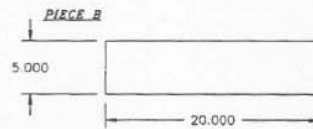
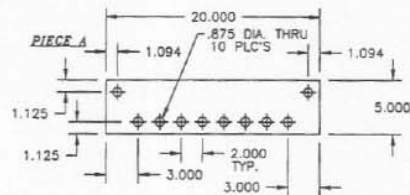

FIGURE 24 — Suggested Grid Designs for the MT-4A and MT-2A Systems.

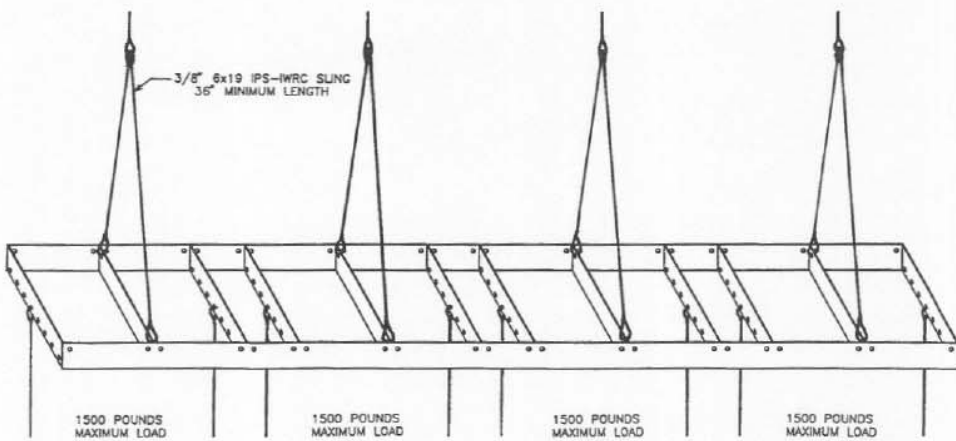
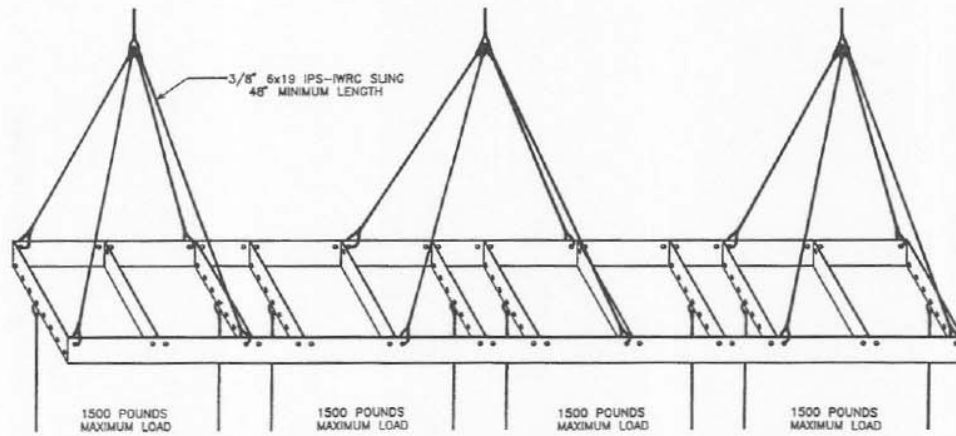
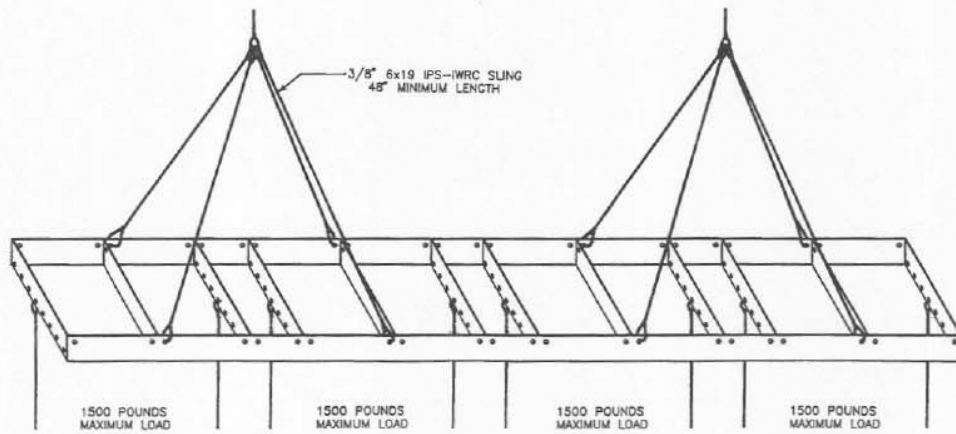

FIGURE 25A — Suggested Rigging Configurations for the Four-Column MT-4A/MT-2A Grid

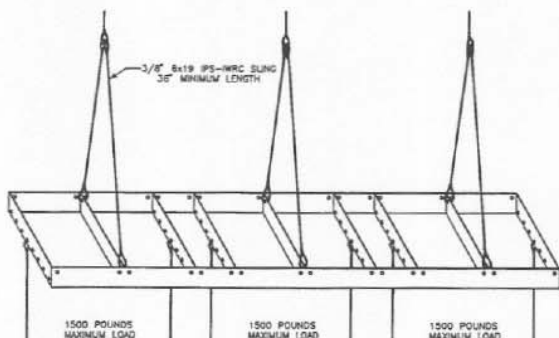
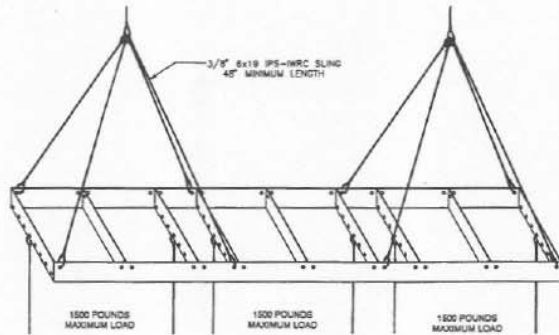
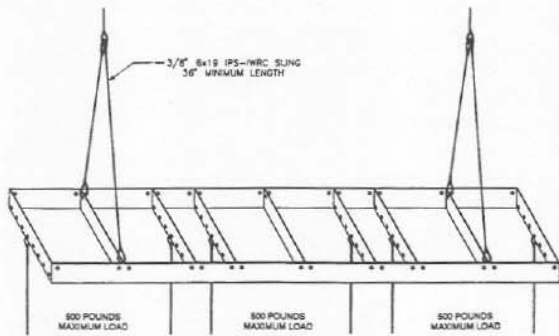

FIGURE 25b — Suggested Rigging Configurations for the Three-Column MT-4A/MT-2A Grid

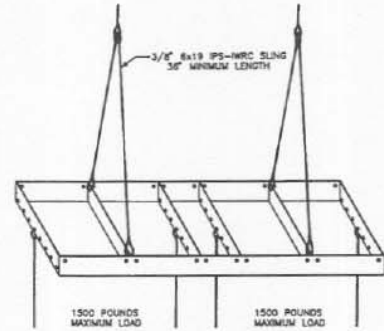
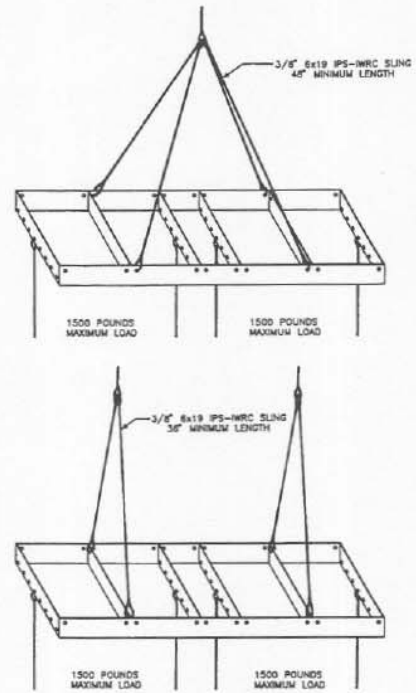

FIGURE 25c — Suggested Rigging Configurations for the Two-Column MT-4A/MT-2A Grid

STRENGTH RATINGS, SAFETY FACTORS AND SPECIAL CONSIDERATIONS

Strength Ratings and Safety Factors

There are two independent strength ratings that, together, give a complete description of the overall structural performance capabilities of any MT loudspeaker system. They are defined as follows:

1. **The strength of each individual rigging point;** which, effectively, is the combined strength of the rigging track mounted on the enclosure and the quick-release rigging-strap assemblies.
2. **The total strength of the enclosure;** which is a function of the combined forces from each of the rigging points acting on the enclosure as a whole.

Electro-Voice provides strength ratings for the MT loudspeaker systems in two formats; the "ultimate-break strength" (i.e., the force required to cause structural failure of the loudspeaker enclosure or rigging hardware) and the "working-load limit" based on a 5:1 safety factor (i.e, the actual ultimate-break-strength ratings divided by a factor of 5). The ultimate-break-strength ratings should be used when calculating the actual safety factor of an array (by comparing the actual forces acting on the loudspeaker enclosure and rigging hardware to the ultimate-break strength of the enclosure and hardware). The working-load-limit ratings are useful in those circumstances where there is a given requirement that an MT loudspeaker array must meet or exceed a safety factor of 5:1 (minimum safety-factor requirements of 5:1 are common in local, state and federal regulations). This requirement is met if the actual forces acting on the loudspeaker enclosures and rigging hardware do not exceed the working-load limits. The use of the working-load limit can save time over safety-factor

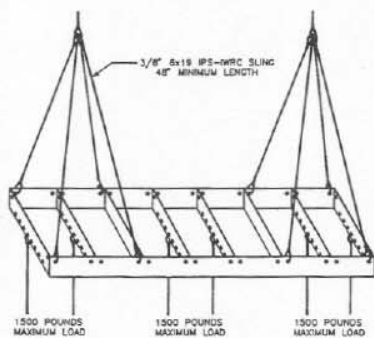
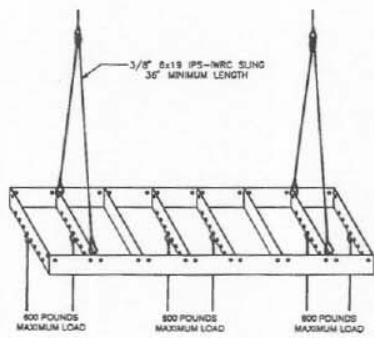
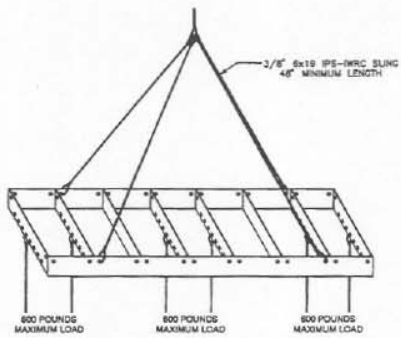

FIGURE 26a — Suggested Rigging Configurations for the Three-Column MT-2A Grid

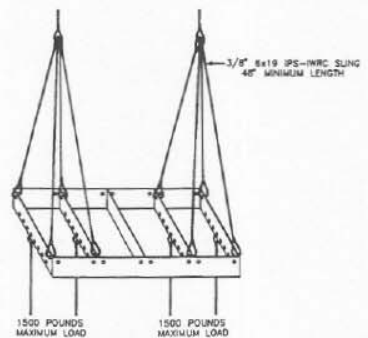
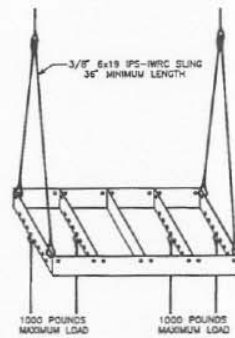
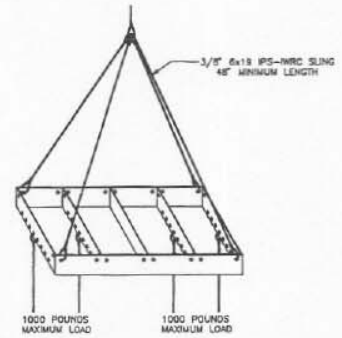

FIGURE 26b — Suggested Rigging Configurations for the Two-Column MT-2A Grid

calculations when it is only necessary to know if the array meets or exceeds minimum requirements of a 5:1 safety factor. If, however, the requirements are for a safety factor other than 5:1, the safety factors must be calculated directly using the ultimate-break-strength ratings.

The ultimate-break strength of each individual rigging point on the MT enclosures is dominated by the strength of the rigging-attachment hardware (the rigging track on the enclosure and the quick-release rigging-strap assemblies) and is independent of the angle of pull. **The ultimate-break-strength rating for each rigging point on the MTL-4AF-series, MTH-4AF-series, MTL-2ACF, MTH-2/94ACF and MTH-2/64CF enclosures is 4,000 pounds when used with the GS-1A, LS-1A or LS-2A rigging accessories (or when used with the Kinedyne #32111-1 or #32102-1 double-stud ring fittings), except at the extreme end positions of the track where the rating is 3,750 pounds.** (Note that the GS-1A, LS-1A or LS-2A rigging accessories use the Kinedyne #32111-1 fittings.)

The actual break strength of an MT-4A or MT-2A enclosure will depend on the combined forces from each of the rigging points acting on the enclosure as a whole and will vary with the array configuration (relative angles of the cabinets, relative angles of the rigging straps, the weight of each loudspeaker system strung together in a vertical array, the weight distribution throughout the array, etc.). **We will define the minimum-ultimate-break strength of the overall MTL-4AF-series, MTH-4AF-series, MTL-2ACF, MTH-2/94ACF and MTH-2/64CF enclosures as 8,000 pounds when used with the GS-1A, LS-1A or LS-2A rigging accessories (or when used with the Kinedyne #32111-1 or #32102-1 double-stud ring fittings).**

The working-load limit for a 5:1 safety factor for each individual rigging point on the MT-4A and MT-2A enclosures is simply the ultimate-break strength previously given for the individual points divided by a factor of 5 and, like the break strength, is independent of the angle of pull. **The working-load limit for each rigging point on the MTL-4AF-series, MTH-4AF-series, MTL-2ACF, MTH-2/94ACF or MTH-2/64CF enclosures is 800 pounds when used with the GS-1A, LS-1A or LS-2A rigging accessories (or when used with the Kinedyne #32111-1 or #32102-1 double-stud ring fittings), except at the extreme end positions of the track where the rating is 750 pounds.**

The working-load limit (for a 5:1 safety factor) of an MT-4A or MT-2A enclosure is simply the ultimate-break strength previously given for the overall enclosure divided by a factor of 5. **The working-load limit of the overall MTL-4AF-series, MTH-4AF-series, MTL-2ACF, MTH-2/94ACF and MTH-2/64CF enclosures is 1,600 pounds when used with the GS-1A, LS-1A or LS-2A rigging accessories (or when used with the Kinedyne #32111-1 or #32102-1 double-stud ring fittings).**

The ultimate-break-strength rating for the individual rigging points on the older MTL-2CF, MTH-2/94CF, MTL-4F-series and MTH-4F-series systems is 4,000 pounds at any angle of pull when used with the GS-1A, LS-1A or LS-2A rigging accessories (or when used with the Kinedyne #32111-1 or #32102-1 double-stud ring fittings), except at the extreme end positions of the track where the rating is 3,000 pounds. The overall enclosure ultimate-break-strength rating for all of the systems is 8,000 pounds. For a 5:1 safety factor, this results in a working-load limit for each individual

rigging point of 800 pounds at all mid track positions and 600 pounds at the extreme end positions of the track. The working-load limit for the overall enclosures then becomes 1,600 pounds.

The user is cautioned that there were errors in the strength ratings given in the original printing of the "MT-4 FLYING OPTION USER'S GUIDE" (EV Part No. 530761) and the "ADDENDUM TO THE MT-4 FLYING OPTION USER'S GUIDE - FLYING THE MT-2" (EV Part No. 531470). Complete strength-rating specifications for both the newer and older versions are presented in this manual. Hence, **the user should use the specifications given in this manual when designing arrays for any of the MT-2, MT-4, MT-2A and MT-4A loudspeaker systems.**

Electro-Voice strongly urges that the user maintain a safety factor of at least 5:1 when implementing an MT flying system. Currently in the United States, OSHA (the Occupational Safety and Health Act) requires a minimum of 5:1 for overhead lifting in the workplace, while ANSI (American National Standards Institute) suggests a minimum of 5:1 for mechanical-component and equipment ratings. The safety factor is defined as the ratio of the ultimate-break-strength rating of the system to the actual applied load. In other words, the ultimate-break strength of each of the mechanical components in the system must be at least five times greater than the actual force applied to those components. The weakest component of an MT flying system determines the strength of the entire system. This includes the MT enclosures, the quick-release rigging hardware, the rigging-strap assemblies, the grid, the hoist and all mechanical components and hardware.

Array Considerations

The techniques discussed in the previous sections for constructing arrays, as shown in Figures 19 through 23, may be expanded upon to create different arrays utilizing different combinations of MT-4A and MT-2A loudspeaker systems, as long as a sufficient safety factor is maintained. The user is reminded that the top cabinet in an array supports the weight of all the cabinets hung beneath it and that the weight distribution between the rigging points will depend on the exact configuration. For example, the center of gravity of the MTH-4A system is not perfectly centered, but rather shifted slightly towards the midrange/high-frequency side of the box. As a result, the load on the GS-1A rigging strap at the top of the midrange/high-frequency side of the MTH-4A column in Figure 18a would be slightly greater than the load on the GS-1A strap on the midbass side (777.4 pounds versus 702.6 pounds). On the other hand, the load would be distributed equally (526 pounds each) between the two GS-1A straps at the top of the MTL-4A column in Figure 18b. The weight distribution of any MT array can be calculated with the information presented in Figure 3. Any users unfamiliar with the process of calculating load distributions should consult reference [1] listed at the end of this manual.

In the previous example of the column of MTL-4A systems in Figure 18b, the worst-case load in the array is the 526 pounds on each of the GS-1A rigging straps at the top of the column. The straps are attached at the #8 position on the enclosure. In that position, the 526-pound load is well within the work-load limit of 800 pounds and results in a safety factor of 7.60:1. If the attachment positions were moved to one of the extreme-end positions of the track (positions #1 or #10), the load would still fall under the

working-load limit of 750 pounds, maintaining a 7.1:1 safety factor. The situation is very much different with the MTH-4A column in Figure 18a, however. The 702.6-pound load on the GS-1A strap at the top on the midbass side and of the column does fall within the 800-pound working-load limit (with a 5.69:1 safety factor) as does the 777.4-pound load on the GS-1A strap on the midrange/high-frequency side (with a 5.14:1 safety factor). If the rigging-attachment points were moved to one of the extreme-end positions of the track, the load on the GS-1A on the midbass side would still fall within the 750-pound working-load limit (having a safety factor of 5.33:1), but the load on the GS-1A on the midrange/high-frequency side would exceed the limit and have a safety factor of only 4.82:1. Thus, a column of four **MTH-4A or (MTH-4) systems should never be suspended overhead using the rigging attachment positions at the extreme ends of the rigging track on the top cabinet.** (The extreme end positions may be used on cabinets other than those at the top.) With large, heavy MT loudspeaker arrays that approach the working-load limit (or the minimum-required safety factor), it becomes increasingly important to be aware of the load distribution throughout the array and which rigging-attachment points are used.

Thus far in the examples given above, only the strength of the individual rigging points has been discussed, while the strength of the overall enclosure has not been touched upon. As defined above, the ultimate-break strength of the overall MT-4A, MT-2A, MT-4 and MT-2 enclosures is always equal to or greater than twice that of the ultimate-break strength of the individual rigging points. As a result, in an array where a number of enclosures are hung one from another in succession, in such a fashion that the top cabinet supports the weight of the entire column and only one rigging-attachment point is used on each track piece on each cabinet, the individual rigging points will always be the determining factor for the ultimate-break strength of the entire array. Thus for any array of the type illustrated in this manual, one need only be concerned about the strength ratings of the individual rigging points.

When arrays are constructed with columns of MT systems oriented with the rigging tracks on the top and bottom of the enclosures (such as those shown in Figure 14, 19 and 20), the rigging straps between the enclosures do not hang straight down with a 0° vertical angle. This is due to the fact the center-to-center spacing of the rigging attachment positions are different from the bottom of one cabinet to the top of the cabinet below. **These vertical-angle differences will result in forces (i.e., tensions) in the rigging straps that are greater than the suspended weight.** These increased forces are, in turn, transmitted to the rigging track and enclosure and must be taken into account when evaluating the safety factor of an array. The greater the angle difference from the 0° vertical, the greater the increase in force, above what it would be if the straps were straight up and down. Any users unfamiliar with the process of calculating the increased load as a function of lifting angles should consult references [1], [2] or [3] listed at the end of this manual.

A time-saving hint to avoid having to calculate the increased forces due to angled rigging straps between cabinets, is to assume the worst-case angle (and, hence the worst-case force increase) for all circumstances. The worst case encountered for any columns of only MTL-4A systems, MTH-4A systems, MTL-2A systems, MTH-2/94A systems or

MTH-2/64 systems when either the LS-1A or LS-2A straps are used, will result in force increases of no more than 4.0 percent in the rigging straps. The worst case encountered for any columns of MTL-4A and MTH-4A systems mixed together, or MTL-2A and MTH-2/94A systems mixed together when either the LS-1A or LS-2A straps are used, will also result in force increases of no more than 4.0 percent in the rigging straps. The worst case encountered for any columns of MTH-2/64 and MTL-2A systems mixed together, or MTH-2/64 and MTH-2/94A systems mixed together when the LS-1A straps are used, will result in force increases in the rigging straps of no more than 32.0 percent. The worst case encountered for any columns of MTH-2/64 and MTL-2A systems mixed together, or MTH-2/64 and MTH-2/94A systems mixed together when the LS-2A straps are used, will result in force increases in the rigging straps of no more than 12.0 percent. Thus the force in the LS-1A straps at the top of the MTH-2/94A enclosure in Figure 14a could be assumed to be 111.3 pounds each, while the force in the LS-1A straps at the top of the MTH-2/64 enclosure in Figure 14b could be assumed to be 135.3 pounds each. Because of the substantial dimensional differences between the MT-2A and MT-4A systems (and, hence, the spacing between the rigging tracks), **MT-2A and MT-4A systems should never be mixed in the same vertical column with the cabinets oriented with rigging track on the top and bottom.**

The user is reminded that the top cabinet of an array supports the weight of all of the cabinets hung beneath it. This generally results in the worst-case forces occurring at the top rigging-attachment point of the top cabinets (including the top rigging straps). However, if the rigging straps throughout the array are at unusual and/or extreme angles, the worst-case forces in an array may occur somewhere other than the top rigging-attachment point of the top cabinets.

Grid/Structural Support Considerations

Note in Figures 25 and 26 that the wire-rope slings supporting the grids are not hanging at a 0° vertical angle. **These vertical-angle differences will result in forces (i.e., tensions) in the slings that are greater than the weight suspended below the slings.** These increased forces must be taken into account when evaluating the load on the grid and the resulting safety factors. Any users unfamiliar with the process of calculating the increased load as a function of lifting angles should consult references [1], [2] or [3] listed at the end of this manual. Also note that, as different rigging-attachment points are selected along the grid cross members to adjust the horizontal angles of the MT loudspeaker systems, the vertical angle of the grid straps may not be 0°, because the grid attachment points may not be located directly above the enclosure rigging points. These vertical angles will result in forces in the straps that are greater than the weight suspended below the straps. These increased forces must be taken into account when evaluating the load on the straps, the rigging-attachment points, the enclosures and the grid, as well as the resulting safety factors.

Electro-Voice offers the grids shown in this manual only as suggestions and offers no guarantee of performance. Variances in the quality of materials and workmanship can substantially affect the strength of the grid. Array details and rigging configurations can also affect the load on the grid. **The user is responsible for determining the strength of**

any constructed grid and the resulting safety factors for all array designs and rigging configurations.

In permanent installations where a grid is not used, the rigging straps and/or slings securing the MT loudspeaker systems to the building supports may not be hanging at a 0° vertical angle. The resulting forces in the straps and/or slings must be taken into account when evaluating the load on the straps, the rigging-attachment points, the enclosures and the building structural supports, as well as the resulting safety factors. Array details and rigging configurations will affect the load on the building structure. **The user is responsible for determining the strength of all building structural supports and the resulting safety factors for all array designs and rigging configurations.**

Rigging-Strap-Assembly Considerations

The ultimate-break-strength ratings given in this manual for the MT-2, MT-4, MT-2A and MT-4A systems are contingent upon using the Kinedyne #32111-1 or #32102-1 double-stud ring fittings for attachment to the rigging track on the MT enclosures. Other products, no matter how similar in appearance, cannot be construed as acceptable substitutes. If substitutions are made, the user assumes the responsibility of determining the strength rating. When the Electro-Voice GS-1A, LS-1A and LS-2A rigging-strap assemblies are used for suspending MT loudspeakers overhead, Electro-Voice will guarantee that the MT enclosure, the rigging track mounted on the enclosure and the entire rigging-strap assembly will meet the ultimate-break-strength ratings given in this manual. If a rigging strap manufactured by someone other than Electro-Voice utilizing the Kinedyne #32111-1 or #32102-1 double-stud ring fittings is used for suspending MT loudspeakers overhead, Electro-Voice will guarantee that the MT enclosure and the rigging track mounted on the enclosure will meet the ultimate-break-strength ratings given in this manual; however, Electro-Voice will make no guarantees of performance of the rigging-strap assemblies. In these circumstances, the user is responsible for determining the strength rating of the rigging-strap assemblies.

The user should be cautioned that the Kinedyne Corporation recommends the use of only the #32111-1 or #32102-1 double-stud ring fittings for overhead lifting. **Kinedyne warns against using the original #32111 and #32102 fittings for overhead lifting because the fittings can disengage from the track while under load when subjected to certain kinds of vibration.** The #32111-1 and #32102-1 fittings are distinguishable from the #32111 and #32102 fittings in that they have a locking pin as shown in Figure 5.

The original Electro-Voice GS-1 and LS-1 rigging strap assemblies utilized the #32111 and #32102 fittings. The GS-1 and LS-1 assemblies can be further recognized as having blue straps, while the newer GS-1A and LS-1A assemblies have green straps. **If you have any of the original Electro-Voice GS-1 or LS-1 rigging-strap assemblies in your possession, you should immediately contact Electro-Voice to have them exchanged at no cost for new GS-1A and LS-1A assemblies.** If you have rigging-strap assemblies manufactured by someone other than Electro-Voice that utilize the #32111 and #32102 fittings, you should immediately contact that manufacturer (or the Kinedyne Corporation directly) to have those assemblies replaced.

The GS-1A, LS-1A and LS-2A rigging-strap assemblies have an identical ultimate-break-strength rating (for a single strap) of 4,000 pounds for any pull angle when used with the MTL-2ACF, MTH-2/94ACF, MTH-2/64CF, MTL-4AF-series MTH-4AF-series systems, except at the extreme end positions of the track, where the rating is 3,750 pounds. This results in a working-load limit of 800 pounds at all mid-track positions and 750 pounds at the end positions. When used with the MTL-2CF, MTH-2/94CF, MTL-4F-series MTH-4F-series systems, the ultimate-break-strength rating of the GS-1A, LS-1A and LS-2A rigging-strap assemblies is 4,000 pounds for any pull angle at all mid-track positions and 3,000 pounds at the extreme end positions. This results in a working-load limit of 800 pounds at all mid-track positions and 600 pounds at the end positions. **These strength ratings are based on a straight tensile pull as typically encountered in the arrays illustrated throughout this manual. Load directions other than straight may result in a significant reduction of strength. The user is responsible for determining the strength ratings in these circumstances.** As an example, such a condition would exist in the array shown in Figure 11 if the top GS-1A straps were pulled in towards each other so far that the straps bent around the top edges of the top cabinet. This condition would also exist if the MTH-4A system in Figure 11 were rotated so that the rigging track appeared on the top and bottom of that cabinet, with the MTL-4A system left with the track on the sides.

Redundant Rigging Hardware

As an added safety measure, it is recommended that the user install a second set of grid straps from the top rigging points of the top cabinets in an array back to the grid (or building structural supports). These redundant safety straps can be secured to an open section of rigging track next to the primary grid straps. The safety straps should have as little slack as possible (less than one inch is preferable).

INSPECTION, MAINTENANCE AND PRECAUTIONS

MT-System Components

MT Loudspeaker Systems. Prior to each use, inspect the loudspeaker enclosures for any cracks, deformations, missing or damaged components which could reduce enclosure strength. Inspect the track and bracket assemblies on the sides of the enclosures for any cracks, deformations, missing or loose screws which could reduce the flying hardware strength. Replace or repair damaged loudspeaker systems. Never exceed the limitations or maximum recommended load specified by Electro-Voice for the MT systems.

Rigging-Strap Assemblies (GS-1A, LS-1A, LS-2A, etc). Prior to each use, inspect the webbing for cuts, abrasion, tears, knots, chemical damage, burns and broken stitches which could reduce rigging-strap-assembly strength. Inspect the fittings and hooks for any cracks, burrs, deformation, missing or damaged components which could reduce strap assembly strength. Replace any rigging-strap assemblies with damaged webbing. Replace or repair any rigging-strap assemblies with damaged hardware. Always double check that each fitting on the rigging-strap assemblies are securely locked into position in the track on the MT enclosures before lifting.

Associated Hardware

Grid Assembly. Prior to each use, inspect the grid assembly and associated hardware for any cracks, deformations, broken welds, corrosion, missing or damaged components which could reduce the grid assembly strength. Replace or repair damaged grid assemblies. Never exceed the limitations or maximum recommended load intended for grid assembly design.

Chain Hoists. Prior to each use, inspect the chain hoist and associated hardware (including motor, if applicable) for any cracks, deformation, broken welds, corrosion, missing or damaged components which could reduce the hoist strength. Replace or repair damaged chain hoists and hardware. Never exceed the limitations or maximum recommended load specified by the hoist manufacturer. Always raise and lower the load slowly and evenly, avoiding any rapid changes in speed or shifting loads that could result in a sudden jolt to the suspended system.

Building Structural Supports. Prior to use, the strength and load-bearing capabilities of the building structural supports should be evaluated and certified by a professional engineer as being adequate for supporting the intended MT system (including the loudspeakers systems, grid, chain hoists and all associated hardware). Prior to each use, inspect the building structural supports for any cracks, deformation, broken welds, corrosion, missing or damaged components which could reduce the structural strength. Damaged building structural supports should be replaced or repaired and re-certified.

Mechanical Components. Prior to each use, inspect all mechanical components (chain, wire ropes, slings, shackles, hooks, fittings, etc.) for any cracks, deformation, broken welds, slipping crimps, fraying, abrasion, knots, corrosion, chemical damage, loose screws, missing or damaged components which would reduce the maximum strength specified by the component manufacturer. Replace or repair any damaged mechanical components.

WARRANTY (Limited)

Electro-Voice MT Speakers and Speaker Systems (excluding active electronics) are guaranteed for five years from date of purchase against malfunction due to defects in workmanship and materials. Electro-Voice MT flying hardware (rigging straps and enclosure-mounted hardware) is guaranteed for one year from date of original purchase against malfunction due to defects in workmanship and materials. Electro-Voice MT accessories (including dollies) are guaranteed for one year from date of original purchase against malfunction due to defects in workmanship and materials. If such malfunction occurs, unit will be repaired or replaced (at our option) without charge for materials or labor if delivered prepaid to the proper Electro-Voice service facility. Unit will be returned prepaid. Warranty does not extend to finish, appearance items, burned coils, or malfunction due to abuse or operation under other than specified conditions, nor does it extend to incidental or consequential damages. Some states do not allow the exclusion or limitation of incidental or consequential damages, so the above exclusion may not apply to you. Repair by other than Electro-Voice or its authorized service agencies will void this guarantee. A list of authorized service centers is available from Electro-Voice, Inc., 600 Cecil St., Buchanan, MI 49107 (616-695-6831); and Electro-Voice West, 8234 Doe Ave., Visalia, CA 93291 (209-651-7777). Or Mark IV Audio Canada, Inc., 345 Herbert St., Gananoque, Ontario K7G2V1 Canada (613-382-2141); Mark IV Audio, A.G., Keltenstrasse 5, CH-2563 Ipsach, Switzerland (41-32-51-6833); Mark IV Vertriebs, GmbH., Larchenstrasse 99, 6230 Frankfurt/Main 80, West Germany (49-69-380-100); Mark IV Audio Japan, Ltd., 2-5-60 Izumi, Sugunami-ku, Tokyo 168, Japan (81-3-325-7900); Electro-Voice, Pty., Unit 24/Block C, Slough Business Park, Slough Ave., Silverwater N.S.W. 2141 Australia (61-2-648-3455). This warranty gives you specific legal rights which may vary from state to state or province to province.

Service and repair address for this product: Electro-Voice, Inc., 600 Cecil St., Buchanan MI 49107.

Specifications subject to change without notice.

REFERENCES

- [1] Rossnagel, W.E., Higgins, L.R. and MacDonald, J.A., "Handbook of Rigging for Construction and Industrial Operations," McGraw-Hill, Inc., 1221 Avenue of the Americas, New York, NY 10020 USA. (1988).
- [2] Newberry, W.G., "Handbook for Riggers," Newberry Investments Co., Ltd., P.O. Box 2999, Calgary, Alberta, Canada T2P 2M7 (1989).
- [3] Glerum, J.O., "Stage Rigging," Southern Illinois University Press, P.O. Box 3697, Carbondale, IL 62902, USA. (1987).
- [4] Vasey, J., "Concert Sound and Lighting Systems," FocalPress, 80 Montvale Ave., Stoneham, MA 02180 USA (1989)