

# 4S/5S Manual (1.2 EN)

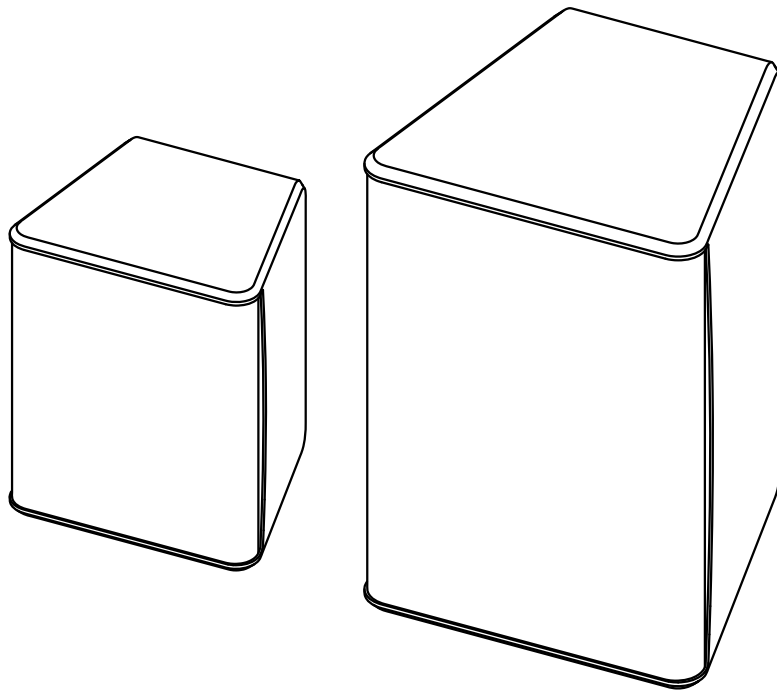

## **General information**

4S/5S Manual

Version: 1.2 EN, 01/2011, D2607.EN .01

Copyright © 2011 by d&b audiotechnik GmbH; all rights reserved.

**Keep this manual with the product or in a safe place so that it is available for future reference.**

When reselling this product, hand over this manual to the new customer.

d&b audiotechnik GmbH  
Eugen-Adolff-Strasse 134, D-71522 Backnang, Germany  
T +49-7191-9669-0, F +49-7191-95 00 00  
docadmin@dbaudio.com, www.dbaudio.com

# Contents

<b>1. Safety precautions.....</b>	<b>4</b>
1.1. Information regarding the use of loudspeakers.....	4
<b>2. 4S/5S loudspeaker.....</b>	<b>5</b>
2.1. Product description.....	5
2.2. Connections.....	5
2.3. Operation.....	6
2.3.1. Controller settings.....	7
2.4. Dispersion characteristics.....	7
2.5. Technical specifications.....	8
<b>3. Manufacturer's Declarations.....</b>	<b>10</b>
3.1. EU conformity of loudspeakers (CE symbol).....	10
3.2. WEEE Declaration (Disposal).....	10

# 1. Safety precautions

## 1.1. Information regarding the use of loudspeakers

### Potential risk of personal injury

Never stand in the immediate vicinity of loudspeakers driven at a high level. Professional loudspeaker systems are capable of causing a sound pressure level detrimental to human health. Seemingly non-critical sound levels (from approx. 95 dB SPL) can cause hearing damage if people are exposed to it over a long period.

In order to prevent accidents when deploying loudspeakers on the ground or when flown, please take note of the following:

- When setting up the loudspeakers or loudspeaker stands, make sure they are standing on a firm surface. If you place several systems on top of one another, use straps to secure them against movement.
- Only use accessories which have been tested and approved by d&b for assembly and mobile deployment. Pay attention to the correct application and maximum load capacity of the accessories as detailed in our specific "Mounting instructions" or in our "Flying system and Rigging manuals".
- Ensure that all additional hardware, fixings and fasteners used for installation or mobile deployment are of an appropriate size and load safety factor. Pay attention to the manufacturers' instructions and to the relevant safety guidelines.
- Regularly check the loudspeaker housings and accessories for visible signs of wear and tear, and replace them when necessary.
- Regularly check all load bearing bolts in the mounting devices.

### Potential risk of material damage

Loudspeakers produce a static magnetic field even if they are not connected or are not in use. Therefore make sure when erecting and transporting loudspeakers that they are nowhere near equipment and objects which may be impaired or damaged by an external magnetic field. Generally speaking, a distance of 0.5 m (1.5 ft) from magnetic data carriers (floppy disks, audio and video tapes, bank cards, etc.) is sufficient; a distance of more than 1 m (3 ft) may be necessary with computer and video monitors.

## 2. 4S/5S loudspeaker

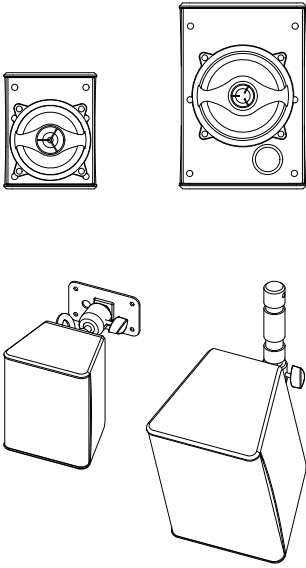

**Fig. 1: 4S/5S loudspeaker rigging examples:**  
4S with Z5401 Wall mount S,  
5S with Z5029 TV spigot

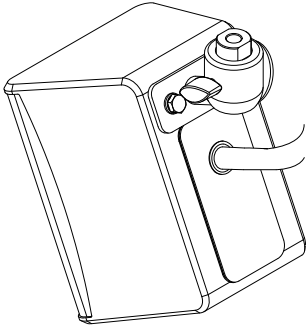

**Fig. 2: Example outdoor use of the 4S cabinet**

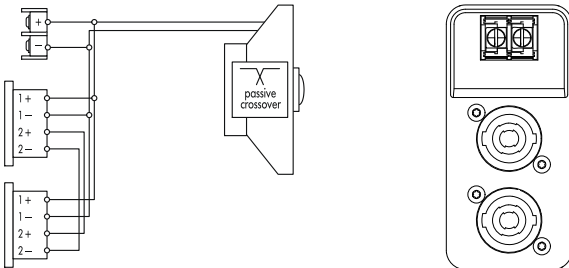

**Fig. 3: Connector wiring**

### 2.1. Product description

The 4S and 5S cabinets are light-weight 2-way passive loudspeakers using coaxially mounted, wide dispersion dome tweeters. The coaxial design offers a symmetrical dispersion pattern in the horizontal and vertical plane while the cabinets may be mounted in either attitude.

The 4S employs a 4" neodymium LF driver in an ultra-compact, sealed enclosure. Its frequency response extends from 130 Hz to 20 kHz.

The 5S comprises a 5" ferrite LF driver in a bass-reflex enclosure covering the range from 80 Hz to 20 kHz.

Both systems can be used stand-alone or supplemented by different subwoofers of the xS-Series.

The enclosures are injection molded with an impact resistant black paint finish. The fronts of the loudspeaker cabinets are protected by a rigid metal grill backed by an acoustically transparent foam.

The 4S and 5S rear panels incorporate two M8 threaded inserts to accept the Z5401 Wall mount S. Using the M10 socket of its ball joint adapter, the loudspeakers can be connected to different d&b mounting accessories such as:

- Z5029 TV spigot,
- Z5034 Stand adapter,
- E6532 Super Clamp,
- Z5035 M10 to 3/8" adapter.

### Intended use

Both cabinets are weather protected and suitable for outdoor use. For unprotected outdoor operation the screw terminals must be used for connection and the cover panels to hide the connector panel (IP34, vertical aiming from +15° to -45°). A detailed description of how to apply the fixed cable connection is given in the following section (⇒ Chapter 2.2. "Connections" on page 5).

For this purpose the 4S cabinet must be installed with the M8 inserts located at the top of the cabinet's rear panel.

### 2.2. Connections

The cabinets are fitted with a pair of NL4 connectors and a two pole screw terminal block (ST - cross-section up to 4 mm<sup>2</sup>/ AWG 11). All four pins of both NLT4 connectors are wired in parallel. The cabinets use the pin assignments 1+/1-. Pins 2+/2- are designated to active subwoofers.

Pin equivalents of the applicable connector options are listed in the table below.

NL4	1+	1-	2+	2-
ST	+	-	n.a.	n.a.

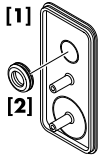

**Fig. 4: Cover plate and rubber grommet**

### Fixed cable connection

The 4S and 5S loudspeakers are each supplied with a cover plate [1] and a rubber grommet feed through [2]. For indoor operation, these items can be used to hide the connector panel, if required. For unprotected outdoor operation, the connector panel must be covered, i.e. both items must be used to achieve an IP degree of protection of IP34.

To install the fixed cable connection, proceed as follows:

1. Prepare the rubber grommet and the connection cable.
2. Remove the knockout opening in the cover plate and attach the rubber grommet correspondingly.
3. Insert the connection cable through the rubber grommet and connect the cable wires to the screw terminal.  
⇒ Observe the correct polarity!
4. Push the cover plate towards the connector panel until the two spigots of the cover plate are in line with the center holes of the two NL4 connectors.
5. Finally push the cover plate towards the cabinet until it completely fits into the recess of the connector panel.



**Fig. 5: Installing the fixed cable connection**

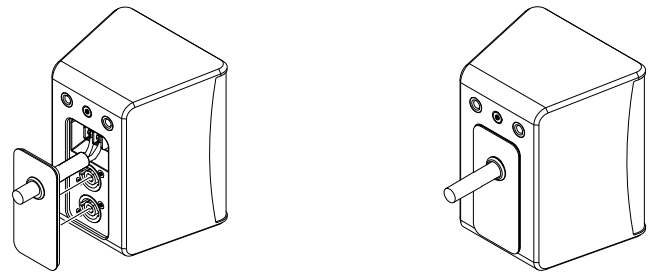

## 2.3. Operation

### NOTICE!

Only operate d&b loudspeakers with a correctly configured d&b amplifier, otherwise there is a risk of damaging the loudspeaker components.

### Operation with D6 or D12

Select the controller setup 4S for 4S loudspeakers and 5S for 5S loudspeakers.

Within the D12 amplifier they are available in "Dual Channel" or "Mix TOP/SUB" mode. For combinations with active subwoofers fed by a single 4-wire cable "Mix TOP/SUB" mode must be selected.

Up to a total of four 4S or 5S loudspeakers can be driven by each channel of the D6 or D12 amplifiers.

### 2.3.1. Controller settings

For acoustic adjustment the functions CUT, HFA and CPL can be selected.

#### CUT circuit

Set to CUT, the cabinet low frequency level is reduced. The cabinets are now configured for use with d&b active subwoofers.

#### HFA circuit

In HFA mode (High Frequency Attenuation), the HF response of the system is rolled off. HFA provides a natural, balanced frequency response when a unit is placed close to listeners in near field or delay use.

High Frequency Attenuation begins gradually at 1 kHz, dropping by approximately 3 dB at 10 kHz. This roll off mimics the decline in frequency response experienced when listening to a system from a distance in a typically reverberant room or auditorium.

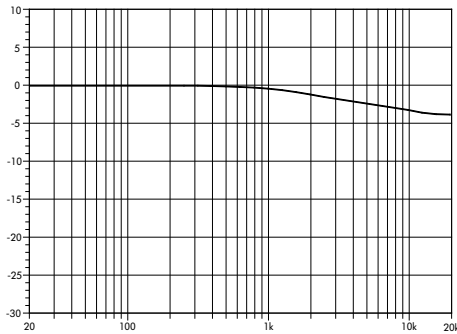

Fig. 6: Frequency response correction of HFA circuit

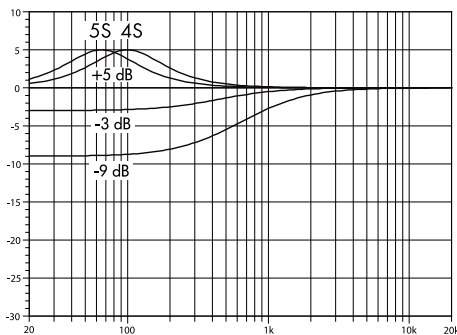

Fig. 7: Frequency response correction of the CPL circuit

#### CPL circuit

The CPL (Coupling) circuit compensates for coupling effects between the cabinets when building closely coupled arrays. CPL begins gradually around 1 kHz, with the maximum attenuation below 200 Hz. To achieve a balanced frequency response, the CPL circuit can be set to dB attenuation values between 0 and -9.

Positive CPL values create an adjustable low frequency boost (0 to +5 dB) and can be set when the system is used in full range mode without subwoofers.

### 2.4. Dispersion characteristics

The following graphs show dispersion angle over frequency of a single cabinet plotted using lines of equal sound pressure (isobars) at -6 dB and -12 dB.

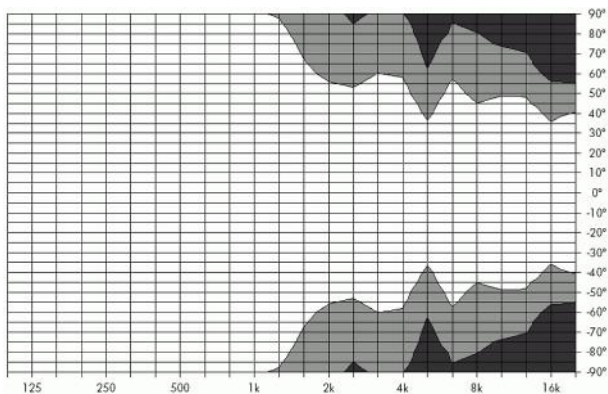

Fig. 8: Isobar diagram horizontal



4S

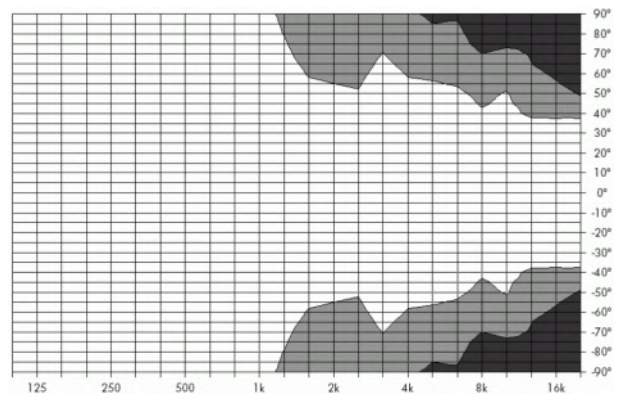

Fig. 9: Isobar diagram vertical

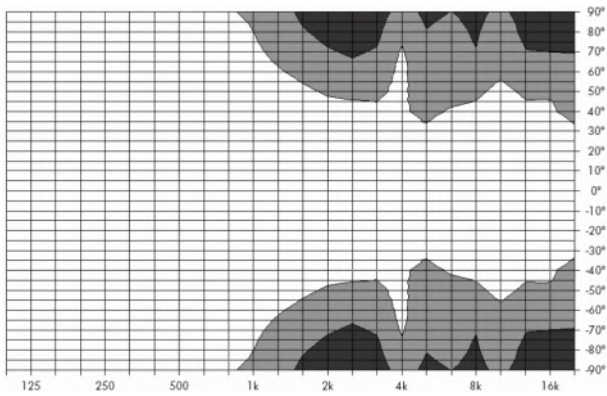
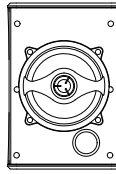

Fig. 10: Isobar diagram horizontal



5S

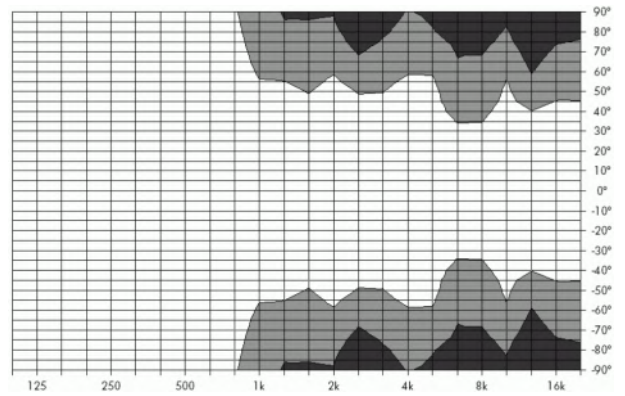

Fig. 11: Isobar diagram vertical

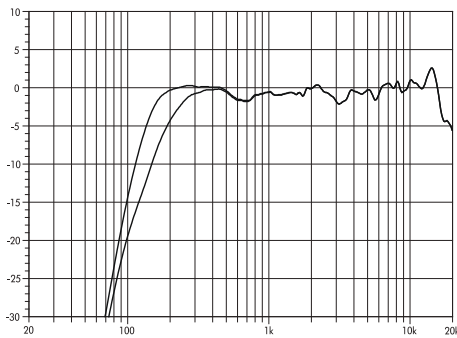

Fig. 12: 4S frequency response, standard and CUT modes

## 2.5. Technical specifications

### 4S system data

Frequency response (-5 dB standard mode)	130 Hz - 20 kHz
Frequency response (-5 dB CUT mode)	180 Hz - 20 kHz
Max. sound pressure (1 m, free field) with D6	114 dB
Max. sound pressure (1 m, free field) with D12	115 dB
	(SPLmax peak, pink noise test signal with crest factor of 4)
Input level (100 dB-SPL/1 m)	-4 dBu

### 4S loudspeaker

Nominal impedance	16 ohms
Power handling capacity (RMS/peak 10 ms)	60/400 W
Nominal dispersion angle (hor. x vert.)	100° conical
Components	4" driver with neodymium magnet
	0.75" dome tweeter, coaxially mounted
	Passive crossover network
Connections	2 x NL4
	1 x screw terminal block (ST - up to 4 mm <sup>2</sup> /AWG 11)
Pin assignments	NL4: 1+ / 1-
Weight	1 kg (2.2 lb)

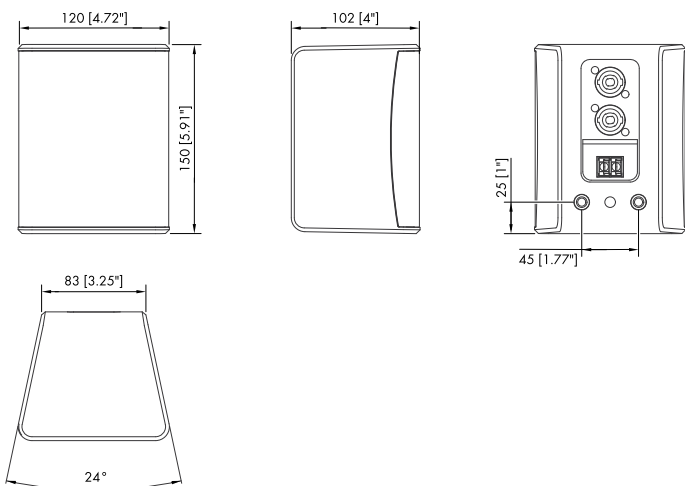
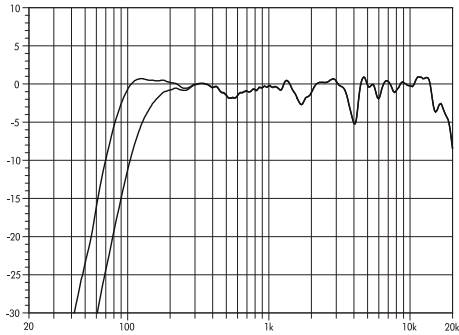

Fig. 13: 4S cabinet dimensions in mm [inch]

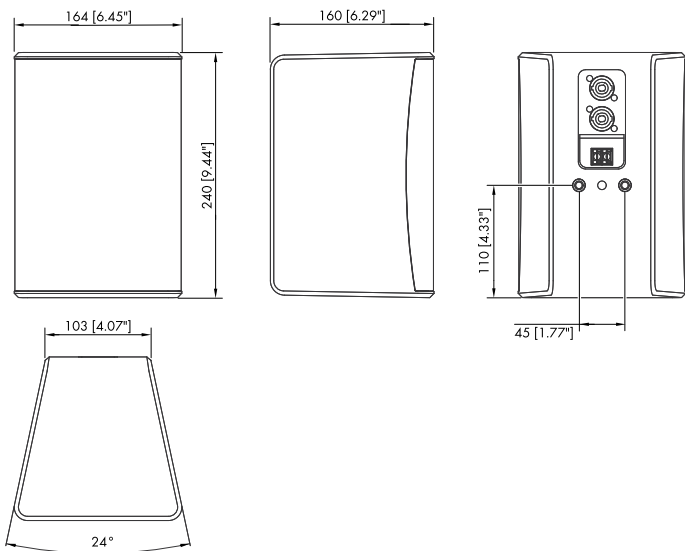



**Fig. 14: 5S frequency response, standard and CUT modes**

**5S system data**

Frequency response (-5 dB standard mode) .....	80 Hz - 20 kHz
Frequency response (-5 dB CUT mode) .....	130 Hz - 20 kHz
Max. sound pressure (1 m, free field) with D6.....	117 dB
Max. sound pressure (1 m, free field) with D12.....	118 dB
..... (SPLmax peak, pink noise test signal with crest factor of 4)	
Input level (100 dB-SPL/1 m).....	-6 dBu



**Fig. 15: 5S cabinet dimensions in mm [inch]**

**5S loudspeaker**

Nominal impedance.....	16 ohms
Power handling capacity (RMS/peak 10 ms) .....	60/400 W
Nominal dispersion angle (hor. x vert.).....	100° conical
Components.....	5" driver with ferrite magnet
.....	1" dome tweeter, coaxially mounted
.....	Passive crossover network
Connections.....	2 x NL4
.....	1 x screw terminal block (ST - up to 4 mm <sup>2</sup> /AWG 11)
Pin assignments.....	NL4: 1+/1-
Weight.....	2.5 kg (5.5 lb)

### 3. Manufacturer's Declarations



#### 3.1. EU conformity of loudspeakers (CE symbol)

This declaration applies to:

**d&b 4S loudspeaker, Z1510**

**d&b 5S loudspeaker, Z1520**

manufactured by d&b audiotechnik GmbH.

All production versions of these types are included, provided they correspond to the original technical version and have not been subject to any later design or electromechanical modifications.

We herewith declare that said products are in conformity with the provisions of the respective EC directives including all applicable amendments.

A detailed declaration is available on request and can be ordered from d&b or downloaded from the d&b website at [www.dbaudio.com](http://www.dbaudio.com).

#### 3.2. WEEE Declaration (Disposal)

Electrical and electronic equipment must be disposed of separately from normal waste at the end of its operational lifetime.

Please dispose of this product according to the respective national regulations or contractual agreements. If there are any further questions concerning the disposal of this product, please contact d&b audiotechnik.

